

INSTRUCTION MANUAL

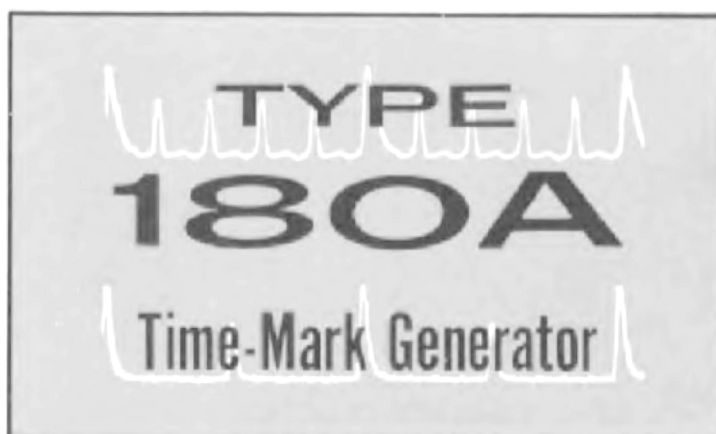

Tektronix, Inc.

S.W. Millikan Way • P. O. Box 500 • Beaverton, Oregon • Phone MI 4-0161 • Cables: Tektronix

070-358

<http://manoman.sqhill.com>



WARRANTY

All Tektronix instruments are warranted against defective materials and workmanship for one year. Tektronix transformers, manufactured in our own plant, are warranted for the life of the instrument.

Any questions with respect to the warranty mentioned above should be taken up with your Tektronix Field Engineer.

Tektronix repair and replacement-part service is geared directly to the field, therefore all requests for repairs and replacement parts should be directed to the Tektronix Field Office or Representative in your area. This procedure will assure you the fastest possible service. Please include the instrument Type and Serial number with all requests for parts or service.

Specifications and price change privileges reserved.

Copyright © 1959. New material Copyright © 1963 by Tektronix, Inc., Beaverton, Oregon. Printed in the United States of America. All rights reserved. Contents of this publication may not be reproduced in any form without permission of the copyright owner.



CONTENTS

Warranty

- Section 1 Characteristics
- Section 2 Operating Instructions
- Section 3 Circuit Description
- Section 4 Maintenance
- Section 5 Calibration Procedure
- Section 6 Parts List and Schematics



Type 180A

SECTION 1

CHARACTERISTICS

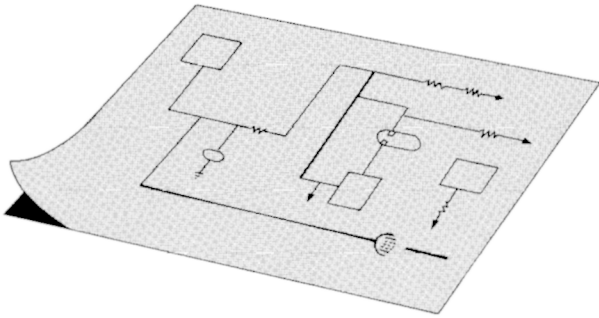

General

The Tektronix Type 180A Time-Mark Generator is a portable laboratory instrument designed to provide accurate time marks, trigger pulses, and sine-wave outputs. The Type 180A may be used in any application where accurate measurement of short time intervals is necessary.

Output Characteristics

Microsecond markers at intervals of 1, 5, 10, 50, 100 and 500 microseconds.

Millisecond markers at intervals of 1, 5, 10, 50, 100 and 500 milliseconds.

One-second and five-second interval markers. Sine-waves

of 5 mc, 10 mc, and 50 mc. Trigger pulses at rates of 1 cps, 10 cps, and 100 cps, 1 kc, 10 kc and 100 kc.

The markers are available individually at banana jacks on the front panel and at a front panel connector labeled MARKER OUT. The individual push-button switches connect the markers to a common bus, so that any or all of the markers can be made available simultaneously at the output. Push-button switches are also provided to connect any one of the three sine-wave outputs to the MARKER OUT connector. Only one sine-wave can be used at a time.

Trigger pulses are available at the TRIGGER OUT connector on the front panel of the Type 180A. The trigger pulses are also selected by the operation of a push-button switch.

TABLE 1-1
For Type 180A, S/N 5479 and up
NOMINAL VOLTAGE, IMPEDANCE, AND RISETIME VALUES

	Open Circuit Voltage	Impedance (at half-voltage)	*Risetime	Open Circuit Voltage	Impedance
Markers	3 volt minimum	390 Ω or less	varies from 0.07 μ sec at 1 μ sec to 1.7 μ sec at 5 seconds	25 volts minimum using 10X probe	390 Ω at 1 μ sec to 680 Ω at 5 seconds
Trigger Pulses	6 volt minimum 8 volt maximum	56 Ω or less	0.08 μ sec at 10 μ sec to 0.30 μ sec at 1 sec		
Sine Waves	3 volt minimum peak-to-peak across 50-ohms				

*With marker out and trigger out terminated in 93 ohms.

TABLE 1-1 S/N 5001-5478
NOMINAL VOLTAGE, IMPEDANCE AND RISETIME VALUES

	Open Circuit Voltage using 10X Probe	Impedance (at half voltage)	*Risetime	Open Circuit Voltage using 10X Probe	Impedance
Time Markers	1.5 V Min.	390 Ω or less	varies from 0.07 μ sec at 1 μ sec to 1.7 μ sec at 5 sec	8 V Min.	390 Ω at 1 μ sec to 680 Ω at 5 sec.
Trigger Pulses	2.0 V Min.	56 Ω or less	0.08 μ sec at 10 μ sec to 0.3 μ sec at 1 sec.		
Sine Waves Using 50 Ω Terminator	5 & 10 MC—2.5 V 50 MC—1.5 V				

Characteristics — Type 180A

Other Characteristics

Crystal Oscillator

Frequency—1 mc \pm 10 cps. May be accurately set for 1 mc. Stability—within 3 parts per million in 24 hours.

Power Requirements

117 or 234 V Nominal Line Voltage
50 to 60 cps, 240 watts.

Mechanical Specifications

Ventilation—filtered, forced air.

Finish—photoetched, anodized panel. Blue vinyl, perforated cabinet.

Dimensions—13 $\frac{1}{2}$ " high, 9 $\frac{3}{4}$ " wide, 17" depth.

Weight—31 pounds.

Accessories

2—93 Ω Cables, BNC both ends, 012-075
1—Clip lead adapter, BNC 013-076
1—3- to 2-Wire adapter, 103-013
1—3-Conductor power cord, 161-010
2—Instruction Manuals, 070-358

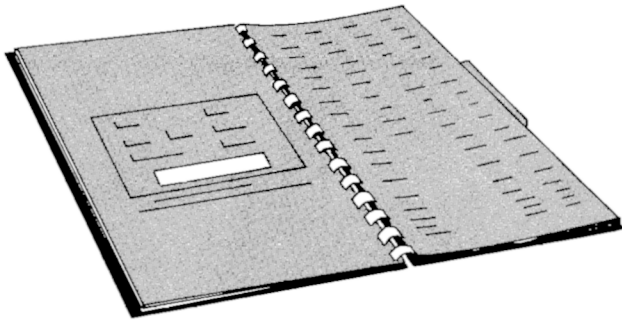

SECTION 2

OPERATING

INSTRUCTIONS

General

The Type 180A may be operated in any normal indoor location, or in the open if protected from moisture. If the instrument has been exposed to dampness, it should be left in a warm room until thoroughly dry before being placed in operation. Operation of the controls also helps to keep the contact surfaces of the switches free from an accumulation of dirt and tarnish.

Cooling

A fan maintains safe operating temperature in the Type 180A Time Mark Generator by circulating air through a filter and over the components. Therefore, the instrument must be placed so that the air intake is not blocked. The air filter must be kept clean to permit adequate air circulation. If the interior temperature should rise too high, for some reason, a thermal cutout switch will disconnect the power and keep it disconnected until the temperature drops to a safe value.

For proper air circulation, the bottom and side panels must be in place. Be sure the bottom panel is installed according to directions.

Power Requirements

A metal plate is attached to the back of your instrument showing the input voltage for which the instrument was originally wired. The regulated power supplies in the Type 180A will operate with line voltages from 105 to 125 volts at 117 nominal line volts, or from 210 to 250 volts at 234 nominal line volts. Proportionate line voltage variations apply when other nominal line voltage primary connections are made. For maximum dependability and long life the voltage should be near the center of this range. Fig. 2-1 shows the connections for the various line voltages.

Voltages outside of these limits, or poor line-voltage waveforms, may cause hum or jitter on the trace and may cause unstable operation. Be sure to check for proper line voltage if indications such as these are present.

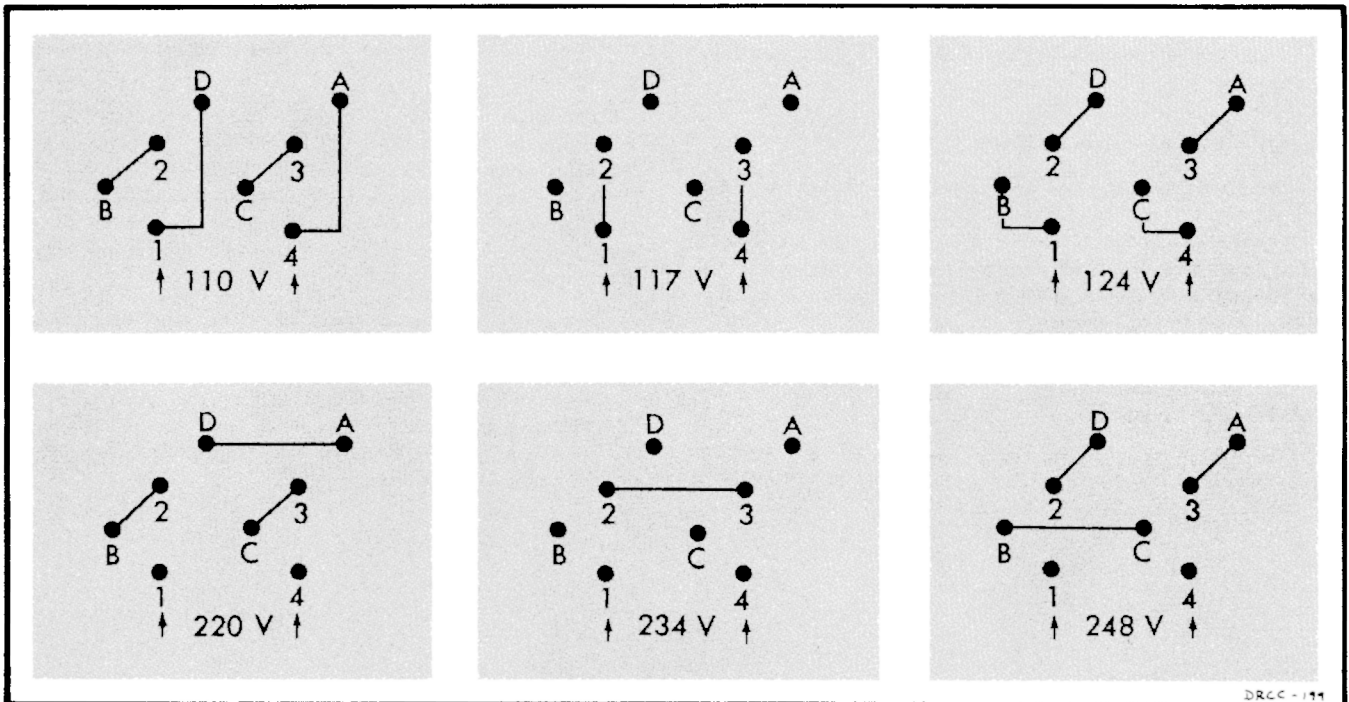

Fig. 2-1 Transformer Primary connections for various line voltages.

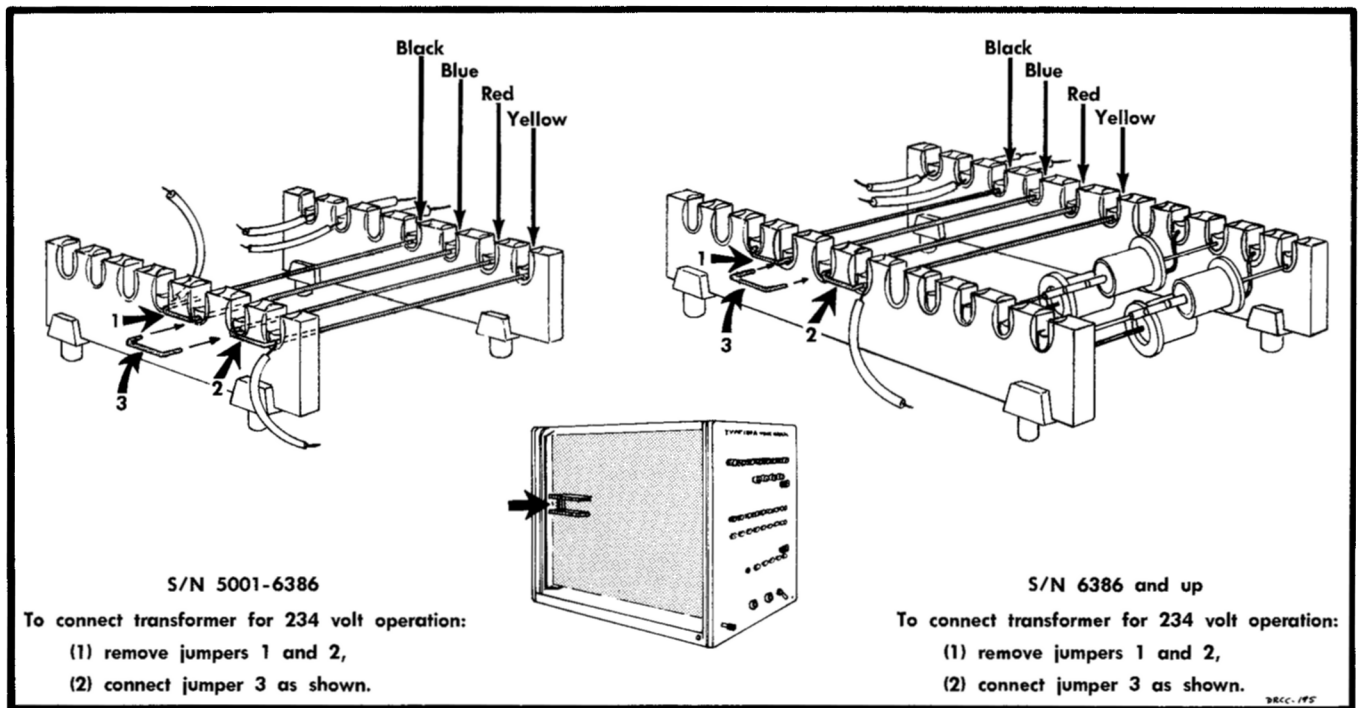

Fig. 2-2 Primary connections for crystal oven transformer, T702. The lower drawing indicates the position of the terminal strips.

Fan Connections

The fan is connected across a portion of the primary of the power transformer and the connections need not be disturbed when changing input line voltages.

Crystal Oven Transformer Connections

The crystal oven transformer has two primary windings which are connected in series for 220 to 248 volt operation as shown in Fig. 2-2.

Signal Output Connections

The time mark signals are connected to the MARKER OUT connector by pushbutton switches. A banana jack is mounted below each switch to provide an additional output connector for each range. The signal appearing at the banana jack is not affected by the operation of the pushbutton for that range.

Keep in mind the type of service for which the time marks are intended when making connections to the MARKER OUT connector.

Table 1-1 in the Characteristics section of this manual shows the output voltages and risetimes available. Type P93

Coaxial Cables are furnished with the Type 180A. If you desire to get the optimum risetime from your instrument you should use a 93 Ω Terminating Resistor at the MARKER OUT connector.

To disconnect a time marker from the MARKER OUT connector, it is necessary to operate the CANCEL pushbutton switch. This will disconnect all of the time markers. Then, you may reconnect the desired time markers to the MARKER OUT connector by operating the appropriate pushbuttons.

Sine-wave outputs of 5, 10 and 50 megacycles are available at the MARKER OUT connector, and are selected by pushbutton switches at the top of the front panel. Each time you operate one of the sine-wave pushbutton switches, it will cancel all of the output signals previously selected and will over-ride any time mark pushbuttons that may be depressed.

Triggering pulses are available separately from a connector on the front panel labeled TRIGGER OUT. Here, too, the output signals are selected by the operation of a pushbutton switch. However, pushing the switch for one range will automatically cancel the range previously selected, and, therefore, only one range of trigger pulses is available at one time.

SECTION 3

CIRCUIT DESCRIPTION

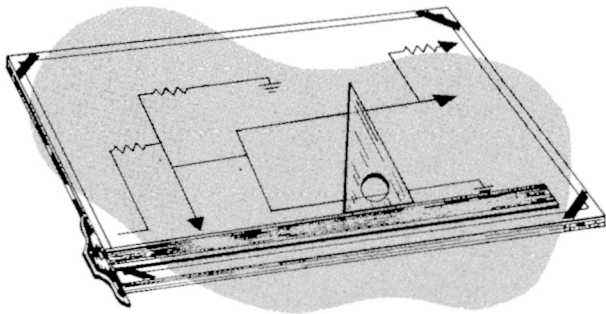

Block Diagram

In the Type 180A, time-marker and sine-wave outputs are derived from a one-megacycle oscillator. The time-marker signals are available individually at banana-jack connectors or in combination at a coaxial connector. The sine-wave signals are available individually at the coaxial connector. In addition, a triggering signal is available at another coaxial connector. The manner in which the circuits are functionally arranged to achieve these ends is shown in Figure 3-1.

The oscillator is an electron-coupled, crystal-controlled oscillator. Its output signal is coupled to the 1- μ sec Amplifier and Cathode Follower and to the Isolating CF. To insure long-term stability, the crystal is housed in a temperature-controlled oven.

In the 1- μ sec Amp and CF stage, the signal is amplified for coupling to the front-panel 1- μ sec banana jack and push-button switch. The output from this stage is also connected to the input of the 5-mc Multiplier.

In the 5-mc Multiplier, the 1- μ sec time markers drive an rf amplifier tuned to 5 megacycles. The resulting 5-mc sine-wave output is coupled to the input of the 10-mc Multiplier, which in turn, drives the 50-mc Multiplier. The 10-mc and 50-mc Multipliers, like the 5-mc Multiplier, are rf amplifiers tuned to the desired output frequency. The sine-wave outputs from all three multipliers are connected to the associated pushbuttons. The pushbuttons are mechanically linked so that only one of the sine-wave signals can be selected at a time. The signal so selected is connected through the pushbutton switches to the MARKER OUT coaxial connector.

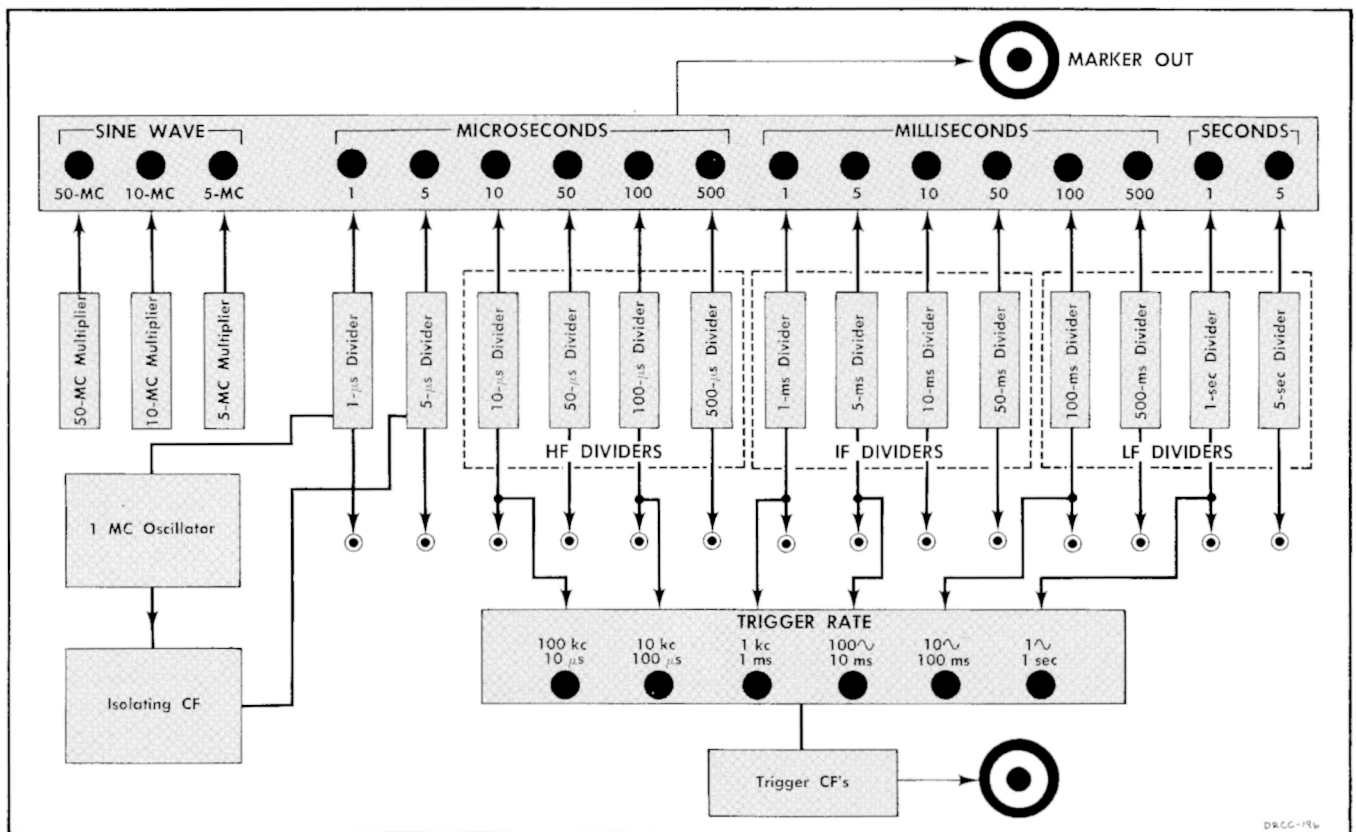

Fig. 3-1 Type 180A functional block diagram.

Circuit Description — Type 180A

The oscillator signal connected to the Isolating CF drives the 5- μ sec Divider. In this circuit, one output pulse is produced for every five input pulses. Since the input signal consists of 1-microsecond pulses, one output pulse will occur every 5 microseconds. The 5- μ sec markers are coupled to the pushbutton switches and banana jacks for external use, and are also connected to the input of the 10-microsecond divider. The 10- μ sec divider produces one output pulse for every two input pulses. Hence with 5- μ sec markers at the input, the output markers will be spaced 10-microseconds apart.

All of the other dividers are similar to the 5- μ sec or 10- μ sec divider. They produce one output pulse for every five or every two input pulses. In this manner, the original 1-microsecond time-marker signal is accurately "counted down" to as low as 5 seconds.

The output signals from all of the dividers are connected to an associated banana jack and pushbutton. The pushbuttons are mechanically linked so that any number may be depressed at one time. A cancel button (not shown in Fig. 3-1) is provided to mechanically release all of the depressed buttons.

The signals at the 10- μ sec, 100- μ sec, 1-msec, 10-msec, 100-msec, and 1-sec banana jacks are also connected to the TRIGGER RATE pushbuttons. Here, any one of the signals may be selected for connection to the TRIGGER OUT connector. The signals are coupled to the coaxial connector through two cathode-followers.

OSCILLATOR AND AMPLIFIER

Oscillator

Circuit details for the oscillator appear on the OSCILLATOR AND MULTIPLIER schematic diagram. The oscillator, V100B, operates as a conventional electron-coupled, crystal-controlled oscillator. The crystal is contained in a temperature-controlled oven. A front-panel lamp, B101, is connected in parallel with the heating element to indicate operation of the thermostat. A variable capacitor, C105, is connected in parallel with the crystal to permit slight adjustments of the crystal resonant frequency.

The output waveform at the plate of V100B is capacitively coupled to the grid of the 1- μ sec Amplifier, V104B, and direct coupled to the Isolating Cathode Follower, V100A. The rc network, R103-C103, increases the risetime of the pulse at the grid of V104A (in comparison to the pulse at the grid of V100A) to insure the coincidence of the 1- and 5- μ sec markers.

1- μ sec Amplifier

The 1- μ sec Amplifier is a conventional voltage amplifier with high-frequency peaking in the plate circuit. The gain of the stage is about 2.5. The inductor, L107, serves to improve the risetime of the output waveform.

1- μ sec Output CF

The 1- μ sec Output CF, V104A, is biased below cutoff through divider R114-R115. This insures that only the fast-rising positive pulses reach the output. The network consisting

of C116 and R116 differentiates the rectangular pulses from the plate of V104B, causing sharp, positive-going pulses to appear at the grid of V104A. These pulses appear at the cathode of V104A as 1- μ sec time markers. From here, they are coupled to the output switching circuits and to the 5-mc Multiplier.

SINE-WAVE MULTIPLIERS

5-Mc Multiplier

The 5-mc Multiplier, V124, is a conventional grid-leak biased, Class-C amplifier, plate-tuned to 5 megacycles. The exciting 1- μ sec (1-megacycle) pulses cause the plate tank circuit to resonate at 5 megacycles. The 5-mc sine-wave is link-coupled from the output tank circuit and fed to the output switch. Plate voltage for the stage is also controlled by the output switch. The switching arrangement is such that V124 will operate only when the 5-, 10- or 50-mc pushbutton is actuated.

10-MC Multiplier

V134 acts as a frequency doubler. The primary and secondary of the rf transformer in the plate circuit of V134 are both tuned to 10 mc. The 10-mc output signal is link-coupled to the output switch, and plate voltage for the stage is also coupled through the output switch. The switching arrangement is such that the stage operates only when the 10- or 50-mc pushbutton is selected.

50-MC Multiplier

The 50-Mc Multiplier, V144, operates as a frequency quintupler. The primary and secondary of the transformer in its plate circuit are tuned to 50 mc. The plate voltage of this stage is turned on only when the 50-mc pushbutton is depressed.

TIME-MARKER DIVIDERS

Basic Multivibrator

There are 13 frequency dividers in the Type 180A, producing thirteen of the fourteen output time markers. (The fourteenth time marker is the original time marker derived from the one-megacycle oscillator output.) The operation of all thirteen dividers is essentially the same. In general, a divider consists of a bistable multivibrator, with diode coupling for triggering pulses, and two cathode-follower output stages. The operation of the 5- μ sec multivibrator is described below. The circuit notation of Figure 3-2 is used for simplification.

In the quiescent state, V2 is held in conduction by the grid-clamping action of V4 and V1 is blocked out of conduction by the fixed grid bias. The plates of V1 and V3 rest at about +225 volts. The cathode of V3 is normally at about +225 volts in the absence of a triggering pulse.

The multivibrator is triggered into its unstable state by a negative-going 50-volt pulse at the cathode of V3. The pulse drives the cathode more negative than the plate, per-

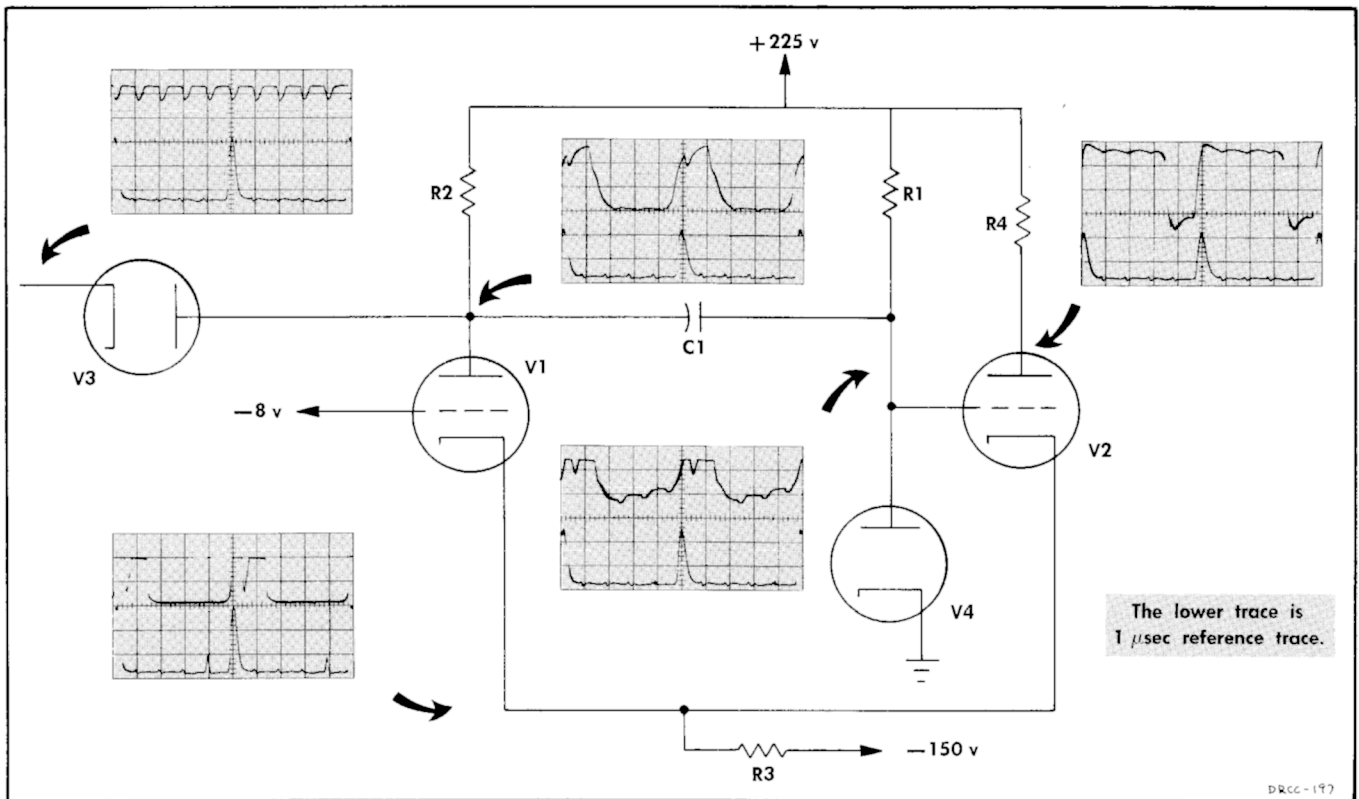

Fig. 3-2 Basic 5- μ sec. multivibrator. Circuit numbers have been changed for simplification.

mitting the tube to conduct. As the tube conducts, the pulse is coupled to the grid of V2 through capacitor C1. The negative pulse breaks the clamping action of V4, driving the grid of V2 negative and causing V2 cathode current to decrease. The decreasing cathode current through R3 causes the cathode voltage of V1 to approach the fixed bias voltage, V1 starts to conduct, causing a further decrease in the voltage at the plate. This negative-going voltage is coupled to the grid of V2 through C1, reinforcing the switching action.

The plate voltage of V1 drops to approximately 175 volts. With the plate of V3 at 175 volts and the cathode at 225 volts, subsequent trigger pulses cannot reach the grid of V2. As the charge on C1 equalizes, the grid voltage of V2 becomes more positive until the clamping action of V4 is restored and V2 begins to conduct. As V2 goes into conduction, the resulting rise in cathode voltage causes V1 to cut off. As the plate voltage of V1 rises, C1 is charged through R2. In the absence of trigger pulses, this would mark the return of the multivibrator to its stable state. The values of R1, R2 and C1 have been selected to provide a lapsed time of approximately 5 microseconds from the time of triggering to the return to the stable state.

As the multivibrator returns to its stable state, the plate of V3 becomes more positive than the cathode, permitting the next trigger pulse to be coupled to the grid of V2.

Isolating CF

The 1-megacycle waveform at the plate of the oscillator, V100B, is coupled to the 5- μ sec Divider through cathode

follower V100A. The function of the cathode follower is to isolate the loading effects of the multivibrator triggering circuit from the oscillator.

5 μ sec Divider

The operation of the 5 μ sec Multivibrator is described in previous paragraphs. Referring to the OSCILLATOR and MULTIPLIER diagram, the 5- μ sec adjustment (R168) determines the charging rate of C167, and hence the elapsed time for one cycle of operation. LR171 in the plate circuit of V165B improves the high-frequency response of the circuit and thereby the leading edge of the output waveform.

The waveform at the plate of V165A is coupled to the 10- μ sec Divider through the Isolating CF, V173B. The purpose of this cathode follower is to prevent signals generated in the 10- μ sec Divider from being coupled back into the 5- μ sec divider.

The output waveform at the plate of V165B is differentiated by C177 and R177, and then coupled to the push-button circuits through the OUTPUT CF. Notice that the grid of V173A is biased at -17 volts. Operating the stage in this manner insures that only the fast-rising parts of the multivibrator waveform are coupled to the output.

10 μ sec Divider

The circuit configuration and operation of the 10- μ sec Divider is essentially the same as the 5- μ sec Divider with one exception. Instead of producing one output pulse for every five input pulses, the 10- μ sec Divider produces one

Circuit Description — Type 180A

output pulse for every two input pulses. This is brought about by the proper selection of circuit time constants.

Other Dividers

All of the dividers in the Type 180A perform in the same manner as the 5- μ sec or 10- μ sec divider. In each divider, time constants have been selected to provide the appropriate duty cycle. Notice that the last divider, the 5-sec Divider, does not have an Isolating CF. This, of course, is because there is no need for a 5- μ sec triggering pulse.

EXTERNAL TRIGGERING

Switching

The manner in which all of the dividers and multiplier output signals are connected to the output terminals is shown on the TRIGGER CF & SWITCHING diagram. Notice that all of the divider Output CFs are connected directly to the banana jacks. Switch connections to the MARKER OUT connector are made through an isolating resistor.

To provide an external triggering signal, switching connections are made directly to the 10- μ sec, 100- μ sec, 1-ms, 100-ms or 1-second banana jacks. These signals are selected by a pushbutton switch in which only one button may be locked in the depressed position. The selected signal is fed to the input of the first TRIGGER CF, and is available at the TRIGGER OUT terminal.

Trigger CFs

The output signal from the first cathode follower is capacity coupled to the grid of the second CF. The dc level of a time-marker signal coupled in this fashion is a function of the signal repetition rate. To avoid wide excursions in the output-signal dc level, a grid-clamping diode is included in the grid circuit of V553B.

Under no-signal conditions, the diode and its associated voltage divider, R560-R561, maintain the grid voltage at approximately -8 volts. Upon the arrival of a positive-going time-marker pulse, the diode ceases to conduct, permitting the grid, and hence the cathode, to follow the signal excursion. At the completion of the pulse, the diode again clamps the grid at about -8 volts. This is true regardless of the pulse repetition rate.

With the grid of V553B always clamped at about -8 volts between pulses, the output pulses at the TRIGGER OUT connector will always start at about 6.5 volts. Their amplitude will depend upon the amplitude of the input signal at the grid of V553A.

POWER SUPPLY

Transformers

Plate and filament power for the tubes in the Type 180A is furnished by a single power transformer, T701. The primary has two equal tapped windings; these may be connected in parallel for 105- to 125-volt operation, or in series for 210- to 250-volt operation. Silicon rectifiers are employed for the three separate full-wave, bridge-type, power supplies. The three supplies furnish regulated

dc voltages of -150 volts, $+225$ volts and $+350$ volts. In addition, -8 volts bias is taken from the -150 volt supply through a voltage divider, and -17 volts bias is taken from the cathode of V433.

A separate transformer, T702, is provided to supply 6.3 volts for the crystal-oven heater. Notice that the primary connections bypass the power switch. This arrangement insures constant crystal-oven temperature even though the power switch may be turned off.

A thermal cut-out is provided in the primary of T701 to open the circuit should the Type 180A internal temperature rise too high. The device is set to open at 137-degrees Fahrenheit. If the cut-out opens, the crystal-oven will operate but the fan and other circuits will not operate. Then, when the internal temperature drops below 137-degrees, the cutout will close, restoring power to the other circuits.

-150 Volt Supply

Reference voltage for the -150 -volt supply is established by a gas diode Voltage-Reference Tube V749. This tube, which has a constant voltage drop, establishes a fixed potential of about -84 volts at the grid of V744B, one-half of a Difference Amplifier. The grid potential for the other half of the Difference Amplifier V744A, is obtained from a voltage divider consisting of R742, R743, and R744. R743, the -150 Adj. control, determines the percentage of total voltage that appears at the grid of V744A and thus determines the total voltage across the divider. When this control is properly adjusted, the output voltage is exactly -150 volts.

Should the loading on the supply tend to change the output voltage, the potential at the grid of V744A will change in proportion, and an error voltage will exist between the two grids of the Difference Amplifier. The error signal is amplified by V744B, whose plate is dc-coupled to the grids of the Series Tubes V757 and V767. The error voltage appearing at the grids of the Series Tubes will change the voltage drop across the tubes and hence change the voltage at the plates of the tubes. This change in voltage at the plates of the Series Tubes, which will be in a direction to compensate for the change in the output voltage, is coupled through the rectifiers and C741 to the output and thus returns the output voltage back to its established value of -150 volts. C744 improves the ac gain of the feedback loop, and thus increases the response of the circuit to sudden changes in output voltage.

$+225$ -Volt Supply

The -150 -volt supply serves as a reference for the $+225$ volt supply. The voltage divider R736-R737 establishes a voltage of essentially zero at the grid of the Amplifier V724. (The actual voltage at this grid will be equal to the bias voltage required by the tube.) If the loading should tend to change the output voltage, an error voltage will appear at the grid of the Amplifier. The error voltage will be amplified and will appear at the grid of the Series Tube V707A. The cathode of V707A will follow the grid, and thus the output voltage will be returned to its established value of $+225$ volts. C736 improves the response of the regulator circuit to sudden changes in output voltage.

A small sample of the unregulated-bus ripple will appear at the screen of V724 through R724. This ripple signal appearing at the screen (which acts as an injector grid) will produce a ripple component at the grid of V707A which will be opposite in polarity to the ripple appearing at the plate of V707A. This tends to cancel the ripple at the cathode of V707A, and hence reduces the ripple on the +225-volt bus. This same circuit also improves the regulation of the circuit in the presence of line-voltage variation.

+350-Volt Supply

The +350-volt supply functions in the same manner as the +225-volt supply. Rectified voltage from terminals 9 and 16 of the power transformer is added to the voltage supplying the +225-volt regulator to supply power for the +350-volt regulator.

Bias-Voltage Supply

The two bias supply voltages are drawn from separate sources. The -17-volt supply is drawn from the cathode of

V433B. C770, connected between the -17-volt supply and ground aids in filtering the output of the supply.

The -8 volts supply is drawn from the R774-R776 divider which is connected across the output of the -150-volt supply.

Color Coding

The power supply circuits can be checked at any point in the instrument by following the color coding of the wires. This coding follows the standard RMA system. Negative voltages from the supply are carried in wires with a black base color while white wires are used for positive voltages. For example, -150 is found on black with a brown and a green tracer stripe while +225 will be found on white with two red tracers. (The last figure is not indicated). The +350 volts will be found on white with an orange and a green tracer.

The bias voltages do not follow the coding system, however. The -8 volt bias will be found on white with a black tracer, and -17 volts will be found on white with grey tracer.

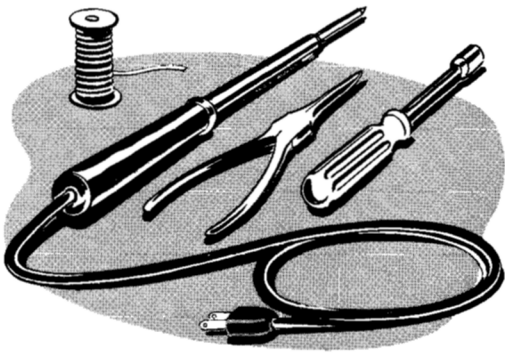

PREVENTIVE MAINTENANCE

Air Filter

Care must be taken to assure free ventilation of the Type 180A inasmuch as some of the components are operated at dissipation levels such that excessive interior temperatures will result without adequate air circulation. To assure free passage of air the instrument must be placed so the air intake is not blocked, and the filter must be kept clean. Moreover, the side panels and bottom cover must be in place for proper air circulation; do not remove the covers except during maintenance.

A washable "E-Z KLEEN" filter is used at the air intake port of the instrument. Under normal operating conditions the filter should be inspected, and cleaned if necessary, every three to four months. More frequent inspection is required when the operating conditions are more severe.

The following cleaning instructions are issued by the filter manufacturer:

1. If grease or dirt load is light, remove filter from installation and rap gently on hard surface to remove loose dirt. Flush remaining dirt or grease out of filter with a stream of hot water or steam; flush from clean side.
2. If load is too heavy for treatment described in (1), prepare mild soap or detergent solution in pan or sink deep enough to cover filter when laid flat. Agitate filter up and down in solution until grease or dirt is loosened and floated off.
3. Rinse filter and let dry.
4. Dip or spray filter with fresh Filter Coat or Handi-Coater. These products are available from the local representative of the Research Products Corporation, and from most air-conditioner suppliers.

Recalibration

The type 180A is a stable instrument and will provide many hours of trouble-free operation. To insure the reliability of measurements obtained on the Type 180A we suggest that its calibration be checked after each 500 hours of operation, or at least every six months if used intermittently. A check of the calibration also provides a means for checking the operation of each circuit. Minor operational deficiencies that are not apparent in normal use are often detected during a calibration check.

Visual Inspection

You should visually inspect the entire instrument every few months for possible circuit defects. These defects may include such things as loose or broken connections, damaged binding posts, improperly seated tubes, scorched wires or resistors, missing tube shields, or broken terminal strips. For most visual troubles the remedy is apparent; however particular care must be taken when heat-damaged components are detected. Overheating of parts is often the result of other, less apparent, defects in the circuit. It is essential that you determine the cause of overheating before replacing heat-damaged parts in order to prevent further damage.

Fan Motor

The fan motor bearings are permanently lubricated and need not be oiled. The fan blade should be cleaned each time the filter is cleaned.

Soldering and Ceramic Strips

Many of the components in your Tektronix instruments are mounted on ceramic terminal strips. The notches in these strips are lined with a silver alloy. Repeated use of excessive heat, or use of ordinary tin-lead solder will break down the silver-to-ceramic bond. Occasional use of tin-lead solder will not break the bond if excessive heat is not applied.

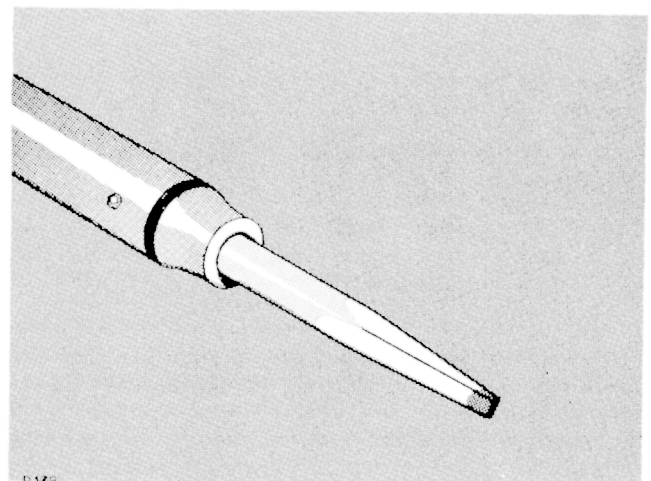

Fig. 4-1. Soldering iron tip properly shaped and tinned.

Maintenance — Type 180A

If you are responsible for the maintenance of a large number of Tektronix instruments, or if you contemplate frequent parts changes, we recommend that you keep on hand a stock of solder containing about 3% silver. This type of solder is used frequently in printed circuitry and should be readily available from radio-supply houses. If you prefer, you can order the solder directly from Tektronix in one pound rolls. Order by Tektronix part number 251-514.

Because of the shape of the terminals on the ceramic strips it is advisable to use a wedge-shaped tip on your soldering iron when you are installing or removing parts from the strips. Fig 4-1 will show you the correct shape for the tip of the soldering iron. Be sure to file smooth all surfaces of the iron which will be tinned. This prevents solder from building up on rough spots where it will quickly oxidize.

When removing or replacing components mounted on the ceramic strips you will find that satisfactory results are obtained if you proceed in the manner outlined below.

1. Use a soldering iron of about 75-watt rating.
2. Prepare the tip of the iron as shown in Fig. 4-1
3. Tin only the first 1/16 to 1/8 inch of the tip. For soldering to ceramic terminal strips tin the iron with solder containing about 3% silver.

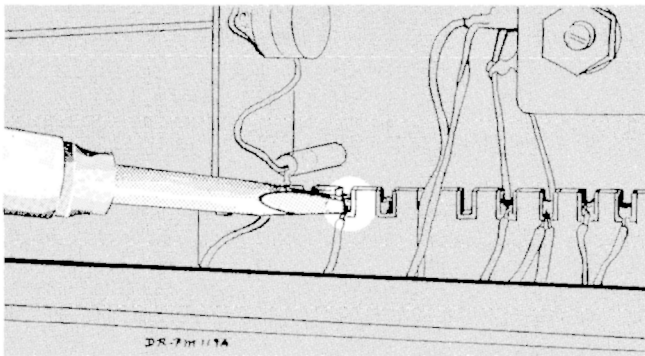

Fig. 4-2. Correct method of applying heat in soldering to a ceramic strip.

4. Apply one corner of the tip to the notch where you wish to solder (see Fig. 4-2).
5. Apply only enough heat to make the solder flow freely.
6. Do not attempt to fill the notch on the strip with solder; instead, apply only enough solder to cover the wires adequately, and to form a slight fillet on the wire as shown in Fig. 4-3.

In soldering to metal terminals (for example, pins on a tube socket) a slightly different technique should be employed. Prepare the iron as outlined above, but tin with ordinary tin-lead solder. Apply the iron to the part to be soldered as shown in Fig. 4-4. Use only enough heat to allow the solder to flow freely along the wire so that a slight fillet will be formed as shown in Fig.4-3.

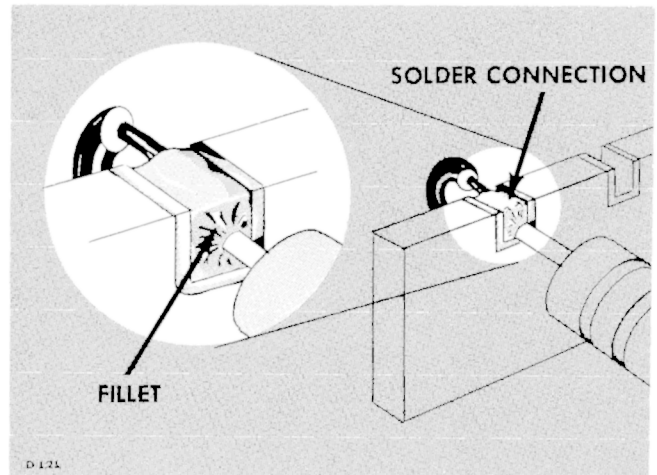

Fig. 4-3. A slight fillet of solder is formed around the wire when heat is applied correctly.

General Soldering Considerations

When replacing wires in terminal slots clip the ends neatly as close to the solder joint as possible. In clipping the ends of wires take care the end remove does not fly across the room as it is clipped.

Occasionally you will wish to hold a bare wire in place as it is being soldered. A handy device for this purpose is a short length of wooden dowel, with one end shaped as shown in Fig. 4-5. In soldering to terminal pins mounted in plastic rods it is necessary to use some form of "heat sink" to avoid melting the plastic. A pair of long-nosed pliers (see Fig. 4-6) makes a convenient tool for this purpose.

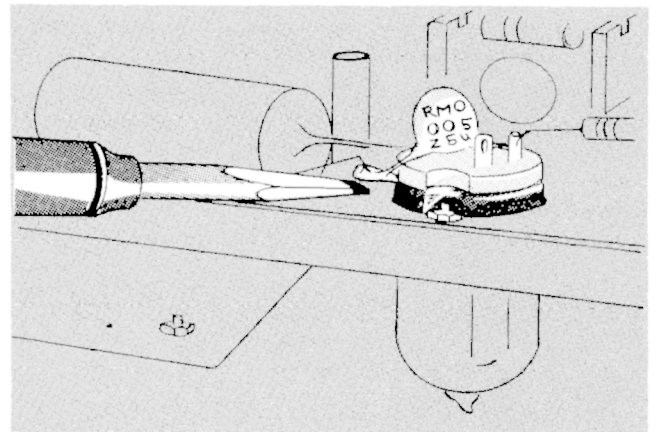

Fig. 4-4. Soldering to a terminal. Note the slight fillet of solder—exaggerated for clarity—formed around the wire.

Ceramic Strips

Two distinct types of ceramic strips have been used in Tektronix instruments. The earlier type mounted on the chassis by means of #2-56 bolts and nuts. The later type is mounted with snap-in, plastic fittings. Both styles are shown in Fig. 4-7.

To replace ceramic strips which bolt to the chassis, screw a #2-56 nut onto each mounting bolt, positioning the bolt so that the distance between the bottom of the bolt and the bottom of the ceramic strip equals the height at which you wish to mount the strip above the chassis. Secure the nuts to the bolts with a drop of red glyptal. Insert the bolts through the holes in the chassis where the original strip was mounted, placing a #2 star washer between each nut and the chassis. Place a second set of #2 flat washers on the protruding ends of the bolts, and fasten them firmly with another set of #2-56 nuts. Place a drop of red glyptal over each of the second set of nuts after tightening.

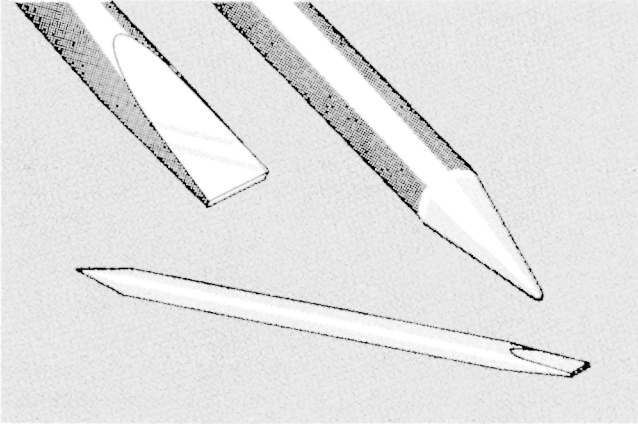

Fig. 4-5. A soldering aid constructed from a 1/4 inch wooden dowel.

Mounting Later Ceramic Strips

To replace strips which mount with snap-in plastic fittings, first remove the original fittings from the chassis. Assemble the mounting post on the ceramic strip. Insert the nylon collar into the mounting holes in the chassis. Carefully force the mounting post into the nylon collars. Snip off the portion of the mounting post which protrudes below the nylon collar on the reverse side of the chassis.

NOTE

Considerable force may be necessary to push the mounting rods into the nylon collars. Be sure that you apply this force to that area of the ceramic strip above the mounting rods.

Cleaning Ceramic Strips

After soldering is completed on ceramic strips, all rosin and other residue should be removed, using Trichloroethylene, Fotocol or other residue-free solvent, applied with a swab or brush.

REPLACEMENT PARTS

Standard Parts

Replacement components can be obtained from Tektronix at current net prices. However, since most of the

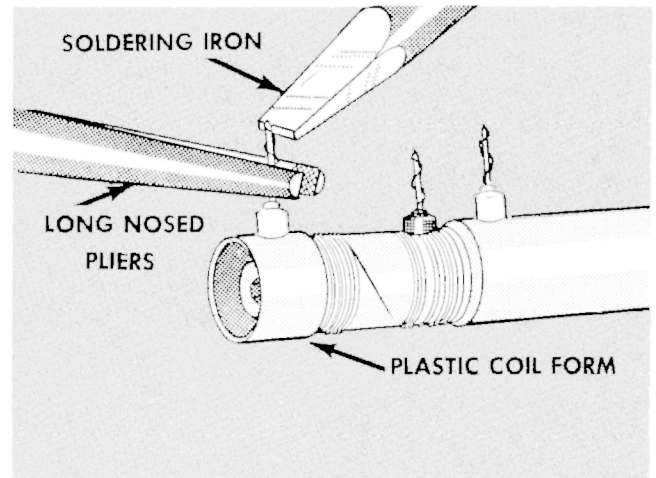

Fig. 4-6. Soldering to a terminal mounted in plastic. Note the use of the long-nosed pliers between the iron and the coil form to absorb the heat.

components are standard electronic and radio parts, they can generally be obtained locally in less time than required to obtain them from the factory. Before ordering or purchasing parts, be sure to consult the parts list to determine the tolerances required.

Tektronix-Manufactured Parts

Tektronix manufactures almost all of the mechanical parts, and some of the electronic components, used in your instrument. When ordering mechanical parts, be sure to describe the part completely to prevent delays in filling your order.

The Tektronix-manufactured electronic components are so noted in the parts list. These components, as well as the mechanical parts, must be obtained from the factory or from the local Tektronix Field Engineering Office.

Replacement information notes sometimes accompany the improved component to aid in its installation.

Each part in your instrument has a 6-digit Tektronix part number. This number, together with a description of the part, will be found in the parts list. When ordering parts, be sure to include both the description of the part and the part number. For example, a certain resistor should be ordered as follows: R110, 220K, 1/2W, Fixed, Comp., 10%, part number 304-224, for a Type 180A Time-Mark Generator, Serial Number _____. When parts are ordered in this manner we are able to fill your order promptly, and delays that might result from transposed numbers in the part number are avoided.

NOTE

Always include the instrument TYPE and SERIAL NUMBER in any correspondence concerning your instrument.

TROUBLESHOOTING AND CIRCUIT ISOLATION

General Information

The following sections contain information necessary for troubleshooting in the Type 180A. Although the Type 180A

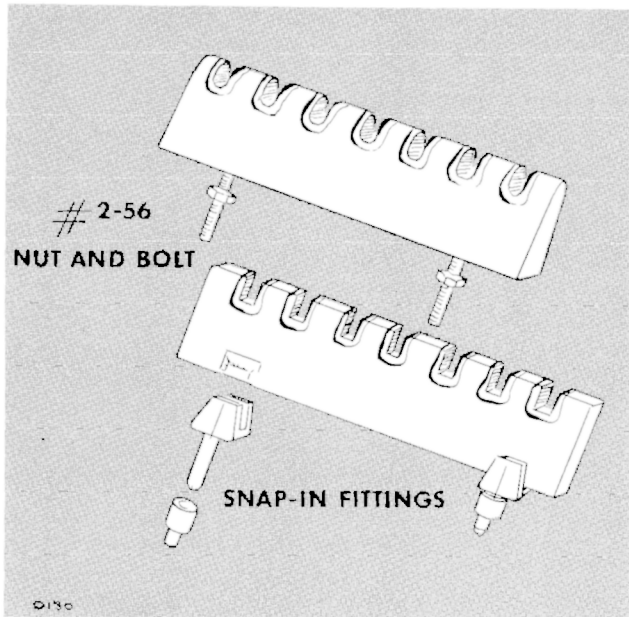

Fig. 4-7. Two types of ceramic strip mountings.

is a complex instrument it can conveniently be divided into basic sections. This division is shown on the Block Diagram of the instrument. The sections that follow describe a method of isolating the trouble to a basic circuit, and then locating the trouble within the basic circuit.

Power Supply

Before attempting to locate a particular trouble in any circuit the power supply should be checked. Proper operation of every circuit within the Type 180A is dependent upon the proper operation of the regulated power supply. Failure of the power supply to regulate properly may appear as an apparent trouble at some other point in the instrument.

If your Type 180A appears to be completely inoperative, make sure that it is properly connected to a source of power. If the pilot lamp on the front panel, and the fan at the rear of the instrument, do not come on when the power switch is turned on, check the source of power, the power cord connection, and the fuse.

If the power supply is receiving the power line voltage correctly, the outputs of the various supplies should be checked next. The power supply outputs can be checked at the points shown in Fig. 5-2. If an improper voltage reading is found, the first thing to suspect is the tubes. Replace all the tubes in the suspected circuit with new tubes. If this cures the trouble, replace the old tubes, one at a time, until the defective tube is found.

If replacing the tubes does not cure the trouble, check the components through which the tube draws current. Shorted tubes sometimes draw enough current to overload

plate-load resistors and cathode resistors. Frequently, a visual inspection of the circuit will reveal burned or discolored parts.

Circuit Isolation

Before attempting to isolate a trouble in either the oscillator or divider circuits, check the operation of the power supply as described in the preceding section. Removal of V162 from its socket, isolates the oscillator and multiplier stages from the divider stages. After removing V162 from its socket use an oscilloscope to check the output at the 1-microsecond banana jack. If one megacycle output is available at the front panel you may assume that the oscillator stage is operating correctly.

Oscillator

If one megacycle output is not available at the front panel, the oscilloscope should be used to trace back through the amplifier stage, V104A, to the crystal oscillator, V100B. If the oscillator waveform appears at the plate of V100B, it should also appear at the cathode of V100A. If you find that the oscillator waveform appears at the cathode of V100A all the circuits are working properly up to that point.

Failure to discover the oscillator waveform at any point indicates trouble in the preceding circuitry. Replacement of tubes should be tried first. If tube replacement does not cure the trouble, the schematic diagram of the circuit should be used as a guide to troubleshooting with a voltmeter.

Dividers

If operation of the oscillator and amplifier is found to be satisfactory, replace V162, and proceed to check the divider stages until you have found the last working stage. The procedure given in Step 3 of the Calibration Procedure can be used to check the operation of the divider stages. Remove the Input Diode which couples the output of the defective stage to the following stages and see if normal operation of the defective stage is resumed. If it is, the trouble is probably due to loading by the following stages, and the trouble should be looked for there.

Replace all the tubes in the defective circuit. If this cures the trouble replace the old tubes, one at a time, until the defective tube is found.

If the trouble does not appear to be due to tubes, use the test oscilloscope to check for triggering signal to the multivibrator. If this is correct, check the output of the multivibrator at the plate of the output triode. If output is present here, check the grid of the cathode follower output stage. If the output signal is found at the grid, proceed to check the cathode. If a loss of signal is noted at the cathode, and if you have tried several tubes with no improvement, the signal path through the switch to the MARKER OUT connector should be checked.

If no output is found at the plate of the multivibrator, and if the signal pulse is being provided correctly, measure the plate voltages at both plates of the multivibrator. The

voltage at the left-hand plate should be equal to the supply voltage (+225 volts). The voltage at the right-hand plate should be down by a considerable amount, possibly as low as +100 volts.

If the plate voltage proves to be correct, measure bias voltage being applied to the grid of the left-hand triode of the multivibrator. This voltage should be between five and seven volts negative.

If these measures fail to locate the trouble in the circuit, a check of the various circuit components is indicated.

Frequency Multipliers

Little difficulty beyond that caused by tubes will normally be found with the multipliers. The Calibration Procedure provides the instructions for adjusting the output of three multiplier stages.

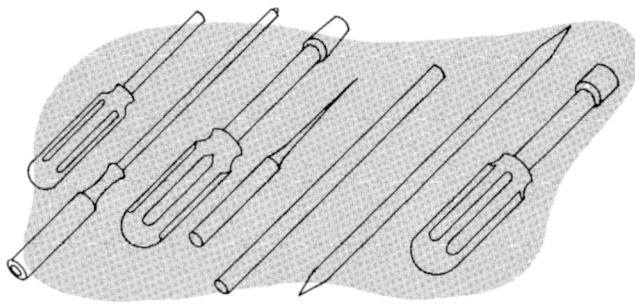

SECTION 5

CALIBRATION

PROCEDURE

General

Normally, it will not be necessary to make all of the adjustments in this procedure at any one time. However, any adjustment which you do make should be made in the indicated sequence.

EQUIPMENT REQUIRED

The following equipment or its equivalent is recommended for a full recalibration of the Type 180A.

1. Tektronix Type 540 Series Oscilloscope, Tektronix Type L Plug-In Preamplifier, or Tektronix Type K Plug-In Preamplifier, and Type B Preamplifier.

If a Type 540 Series is not available, an oscilloscope having the following characteristics may be substituted: Calibrated vertical-deflection factors from .005 volts per centimeter to .2 volts per centimeter; Calibrated sweep rates from .02 microseconds per centimeter to 5 seconds per centimeter; Bandpass of 30 megacycles.

2. Tektronix Type P410 or P6000 Probe.

The Type P410 or P6000 probe has an attenuation ratio of 10:1, an input resistance of 10 megohms, and an input capacitance of approximately 11 $\mu\mu\text{f}$ when connected to a Type B Plug-In Unit.

3. Accurate rms-reading ac voltmeter, 0-150 volts, calibrated for an accuracy of $\pm 1\%$ at 117 volts.

4. Dc voltmeter of at least 20,000 ohms per volt, calibrated for an accuracy of $\pm 1\%$ at 150 volts and 300 volts.

5. An autotransformer (Powerstat, Variac, etc.) capable of varying the line voltage to the instrument being calibrated from 105 to 125 volts.

6. A 50-ohm Terminating Resistor and a Type P93 93-ohm cable.

7. Any good stable communications receiver having a C.W. oscillator.

RECALIBRATION PROCEDURE

1. Power Supply Voltage Adjustment

There are three regulated power supplies in the Type 180A, and two bias supplies. The output voltage of the

—150 volt supply is adjustable and is used as a reference voltage for the +225-volt supply and the +350-volt supply.

The —8 volt bias is taken from the —150 volt supply through a voltage divider. The —17 volt bias is taken from the cathode of V433.

To adjust the output voltages of the supplies, remove the side panels from the cabinet and connect the instrument to the output of the autotransformer. Adjust the autotransformer for an output voltage of 117 volts. Turn the POWER switch of the Type 180A to ON.

To adjust the —150-volt supply connect the meter between ground and the —150-volt supply. Connections to the —150-volt supply should be made as shown in Figs. 5-1 or 5-3. Adjust the —150 ADJ. for an output voltage of exactly —150 volts.

Check the output of the +225-volt supply by connecting the meter between ground and +225 as shown in Fig. 5-1 or 5-3. The output voltage of this supply should be within 2% of 225 volts.

Check the output voltage of the +350-volt supply by connecting the meter between ground and +350-volts as shown in Fig. 5-1. or 5-3. The output voltage of this supply should be within 3% of 350 volts.

To check the output of the —17 volt supply, connect the voltmeter between ground and the —17 volt point as shown in Fig. 5-1 or 5-3. The voltage should be —17 volts ± 2 volts.

Measure between the junction of R774 and R776 and ground to check the —8 volt supply. The voltage should be —8 volts ± 1 volt.

2. Power Supply Ripple

The power supply regulating circuits of the Type 180A are capable of holding the ripple present on the output voltage to a very low level. Measurement of the ripple on the supplies provides a convenient check upon the operation of the regulating circuits.

Set the front-panel controls of the test oscilloscope and plug-in as shown below:

Type 540 Series Oscilloscope

STABILITY
TRIGGERING MODE
TRIGGER SLOPE
TIME/CM
5X MAGNIFIER

PRESET
AUTOMATIC
+ LINE
5 MILLISEC
OFF

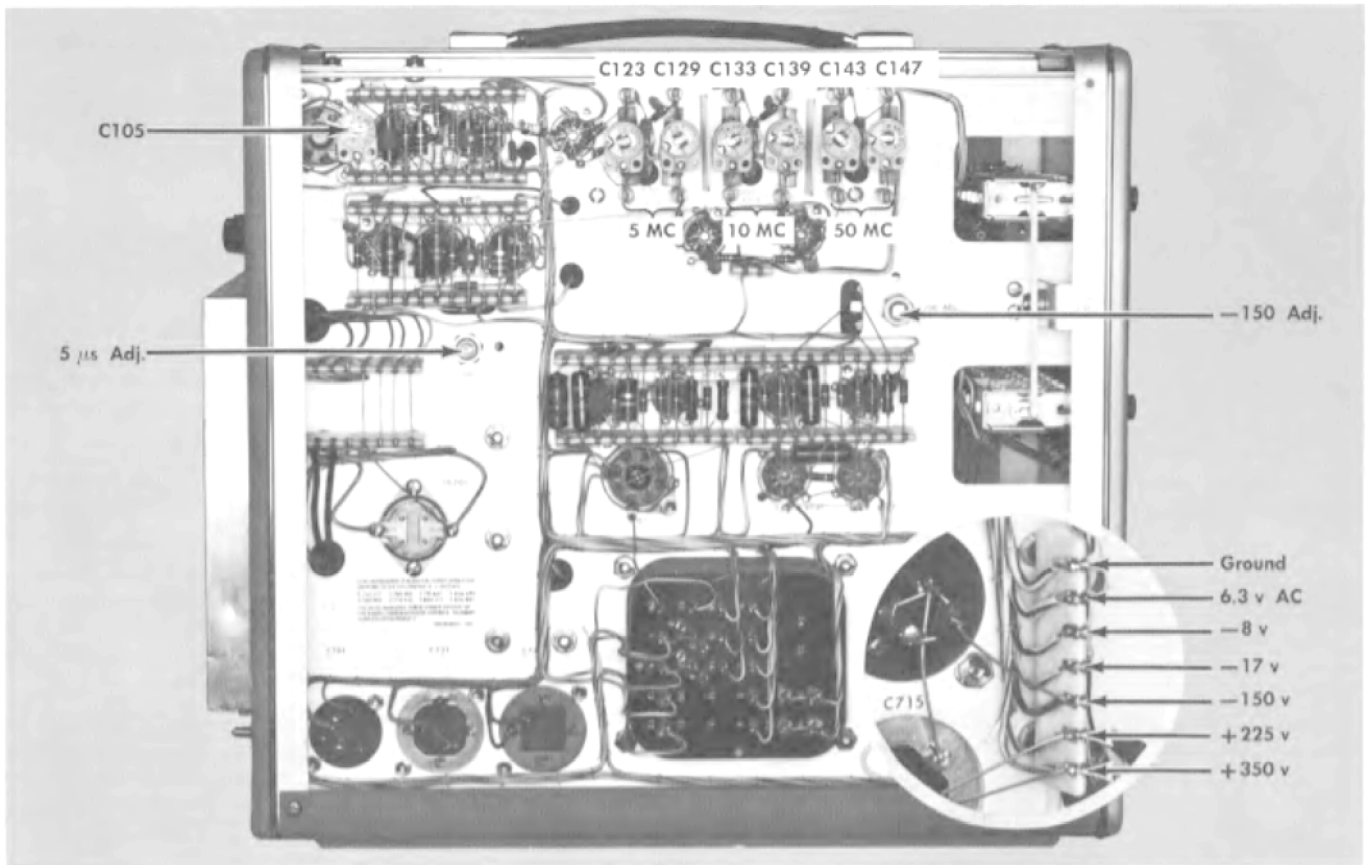

Fig. 5-1 Left side view showing voltage reading points and calibration adjustments. This covers S/N 5001 to 5478.

HORIZONTAL DISPLAY	INTERNAL SWEEP
HORIZONTAL POSITION	centered
POWER	ON
SQUARE-WAVE CALIBRATOR (black knob)	any position
Type B:	
INPUT SELECTOR	INPUT A, AC
VOLTS/CM	.005
VARIABLE	CALIBRATED
VERTICAL POSITION	centered

NOTE

When observing the ripple it will be necessary to take into account any output signal radiating from the oscillator of the Type 180A. This can be minimized by releasing all pushbuttons.

This will show up mostly on the +225 volt supply. To observe the ripple voltage, move the trace down until the top of the trace can be seen. The ripple will appear as a sawtooth on the top of the trace.

On 180A instruments below S/N 6386, the high voltage power supply used selenium rectifiers, which were mounted on the inside of the power supply chassis. There was no change in the operation or calibration procedure due to the change in rectifier types.

To measure the ripple on the -150-volt supply, connect the test oscilloscope input between ground and the -150-volt bus at the point indicated in Fig. 5-1. The Tektronix Type A-100 Clip-Lead Adapter (part number 013-003) or a X1 probe is convenient for this purpose. Vary the line voltage from 105 to 125 volts while viewing the ripple on the test oscilloscope. The ripple should not exceed 10 millivolts at any time.

To measure the ripple on the +225-volt supply, connect the test lead between ground and +225. The ripple present on the output voltage should not exceed 80 millivolts.

To measure the ripple on the +350-volt supply, connect the test lead between ground and +350. The ripple present on the output voltage should not exceed 100 millivolts.

3. Dividing Rate Adjustment

The dividing stages in the Type 180A are cathode-coupled, monostable multivibrators. Potentiometers are provided to adjust the dividing rate of the various stages.

During the adjustment procedure it is necessary to observe the output of the Type 180A on the test oscilloscope.

Use the following front-panel control settings of the oscilloscope and the Type L:

Oscilloscope:	
STABILITY	PRESET
TRIGGERING LEVEL	full right

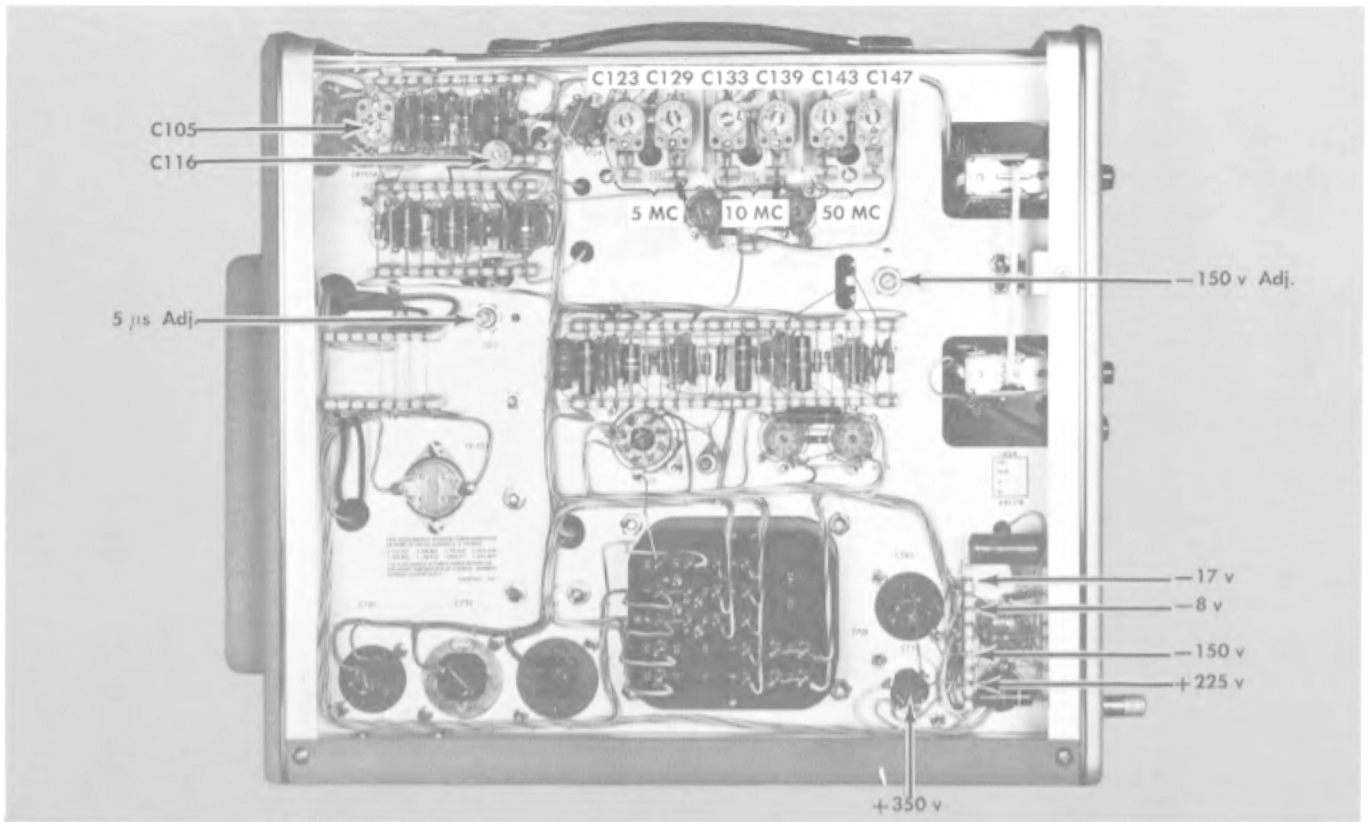

Fig. 5-2 Left side view showing voltage reading points and calibration adjustments. This covers S/N 5479 to 6386.

TRIGGERING MODE	AC SLOW
TRIGGER SLOPE	+EXT
TIME/CM	1 MICROSEC
5X MAGNIFIER	OFF
HORIZONTAL POSITION	centered
HORIZONTAL DISPLAY	INTERNAL SWEEP
POWER	ON
Type L:	
INPUT SELECTOR	INPUT A, AC
VOLTS/CM	.1
VARIABLE	CALIBRATED
VERTICAL POSITION	centered

Connect the Type 6000 or P410 Probe to the INPUT connector of the Type L or K and to the MARKER OUT connector on the Type 180A.

Turn the TRIGGERING LEVEL control of the oscilloscope slowly to the left until the trace reappears. This should result in a stable display. Slight readjustment of the controls may be necessary from time to time, particularly after shifting to a display of different amplitude.

Depress the 1 μsec and 5 μsec buttons and adjust the 5 μsec pot until the count shows as indicated in Table 5-1 for 5 μsec.

As soon as the one and five μsec markers are adjusted for timing, release both buttons by pressing the red button.

Now depress first the one then the red button, and then the five μsec buttons, noting the amplitude of the pulses in each case. Now adjust C116 while the 1 μsec button is depressed so the amplitude is the same as the five μsec markers. When both the one and five μsec markers are displayed at the same time, the one μsec markers will be about 60% as tall as the five μsec markers.

Table 5-1 indicates the necessary front-panel control settings for the test oscilloscope and the Type 180A. It also indicates the appropriate screwdriver adjustment for each setting of the front-panel push button on the Type 180A. To adjust the Type 180A divider circuits, set the front-panel controls as indicated in the table. Then, adjust the corresponding screwdriver adjustment (see Fig. 5-3) for a display similar to the one shown in the right-hand column.

Output amplitude on all ranges should be 4 volts or more. The trigger pulses are supplied from the TRIGGER OUT connector at the bottom of the front panel, and selected by means of the lowest row of push buttons. The amplitude of the trigger pulses may be checked after the dividing rate and amplitude of the multivibrators have been checked. Amplitude of all trigger pulses should be 6 volts or more.

The open circuit voltage at the pin-jacks under each push button will be about 20 to 25 volts.

4. Sine Wave Output Adjustment

The Type 180A provides three sine-wave frequencies: 5 mc, 10 mc, and 50 mc. These are connected to the MARKER OUT connector on the front panel of the Type

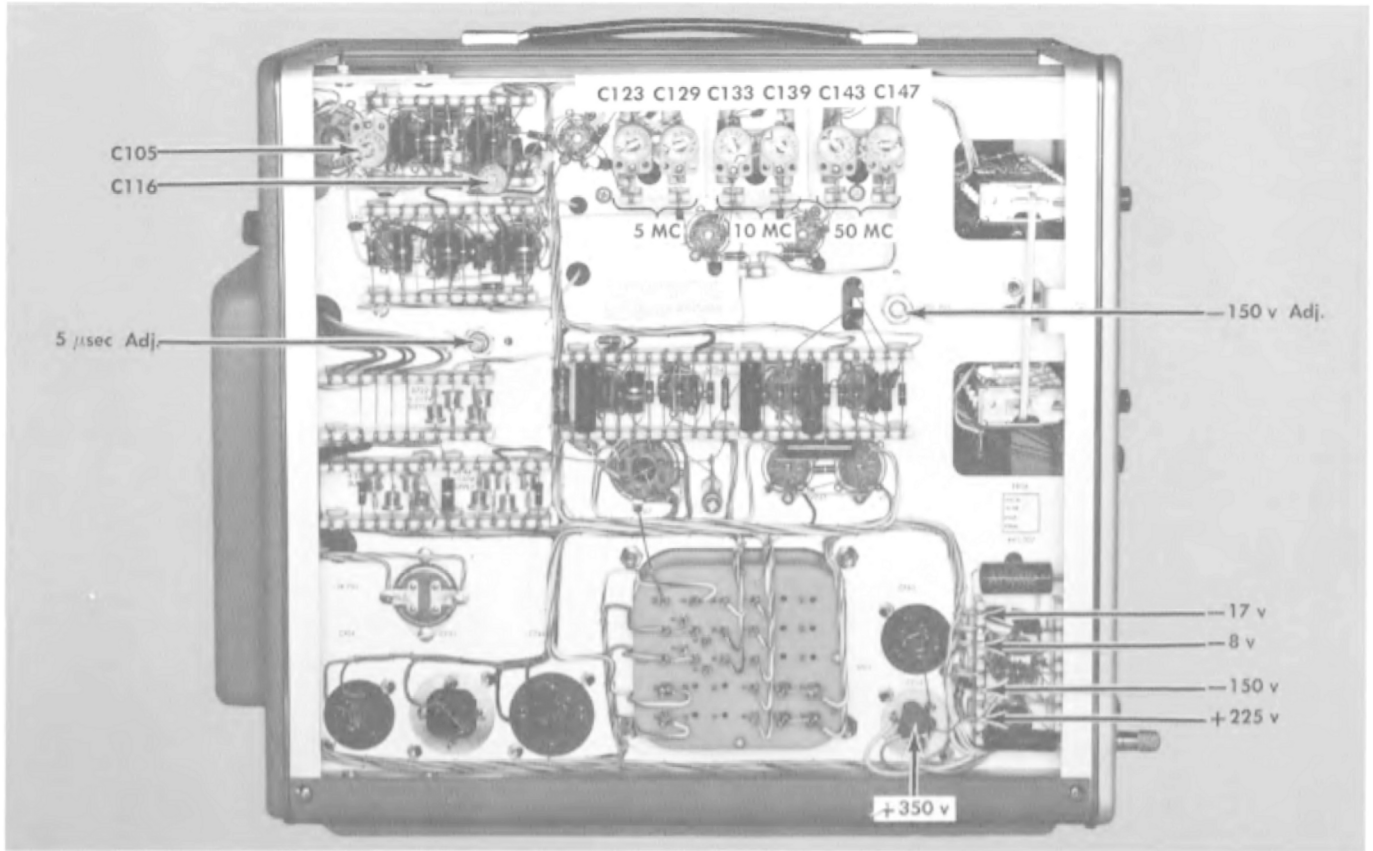

Fig. 5-3 Left side view showing voltage reading points and calibration adjustments. This covers 5/N 6386 up.

180A by means of push button switches. Double-tuned transformers in the plates of the multiplier tubes provide the adjustments for the frequency and output amplitude of the sine-waves.

Make the following front-panel control settings of the Type 540 Series Scope and the Type K or L Unit:

OSCILLOSCOPE:	
STABILITY	PRESET
TRIGGERING LEVEL	full right or full left
TRIGGERING MODE	AC FAST
TRIGGER SLOPE	+EXT
TIME/CM	1 MICROSEC
5X MAGNIFIER	ON
HORIZONTAL DISPLAY	INTERNAL SWEEP
HORIZONTAL POSITION	centered
POWER	ON
SQUARE-WAVE CALIBRATOR	OFF
Type K or L:	
VOLTS/CM	.1
VARIABLE	CALIBRATED
AC-DC	AC
VERTICAL POSITION	centered

Connect the TRIGGER OUT conector of the Type 180A to the TRIGGER INPUT connector of the oscilloscope with a Type P93 cable. Connect the Probe to the INPUT connector of the Type K or L. Connect a 50 Ω Terminating Resistor to the MARKER OUT connector of the Type 180A. Insert the tip of the Probe into the Terminating Resistor. Attach the probe ground connection to the body of the terminating resistor.

Display a five-megacycle sine wave.

Obtain a stable display on the test oscilloscope. Adjust C123 and C129 (see Fig. 5-3) for a five-megacycle display (one cycle per centimeter) of maximum amplitude (two volts or more).

Display a ten-megacycle sine wave.

Switch the TIME/CM switch of the test oscilloscope to the .1 MICROSEC range and turn the 5X MAGNIFIER to OFF. Adjust C133 and C139 for a ten-megacycle (one cycle per centimeter) display of maximum amplitude.

Switch the 5X MAGNIFIER to ON and display a fifty-megacycle sine wave from the Type 180A. Adjust C143 and C147 for a fifty-megacycle display (one cycle per centimeter) of maximum amplitude. At fifty megacycles, the display will be about 1.2 centimeters in amplitude.

5. Trigger Pulling Adjustment

The Type 180A provides triggering pulses of two volts amplitude. The pulses should be adjusted so that they

TABLE 5-1
TIME-MARKER DIVIDER ADJUSTMENTS

OSCILLOSCOPE TIME/CM	TRIGGER	MARKERS	TYPE 180A ADJUSTMENT	DISPLAYED WAVEFORM
1 μ SEC	100 KC	1 and 5 μ SEC	5 μ S	
2 μ SEC	100 KC	5 and 10 μ SEC	10 μ S	
10 μ SEC	10 KC	10 and 50 μ SEC	50 μ S	
20 μ SEC	10 KC	50 and 100 μ SEC	100 μ S	
100 μ SEC	1 KC	100 and 500 μ SEC	500 μ S	
200 μ SEC	1 KC	500 μ SEC and 1 MS	1 MS	
1 MS	100 cycles	1 and 5 MS	5 MS	
2 MS	100 cycles	5 and 10 MS	10 MS	
10 MS	10 cycles	10 and 50 MS	50 MS	
20 MS	10 cycles	50 and 100 MS	100 MS	
100 MS	1 cycle	100 and 500 MS	500 MS	
200 MS	1 cycle	500 MS 1 SEC	1 SEC	
1 SEC	*	1 and 5 SEC	5 SEC	

* Trigger oscilloscope internally from the displayed waveform.

will not cause pulling of the waveform being observed when the Type 180A is used to provide a source of external triggers.

To adjust the trigger pulses for minimum pulling set the front-panel controls as described in Step 4 to obtain 50 megacycle output. In addition to being marked with the appropriate frequency, each trigger push button is marked with its value in time. For example, the 100 KC trigger button is also marked 10 μ S. Trigger the test oscilloscope from each trigger rate in turn, adjusting the appropriate stage should any sign of trigger pulling be evident. In the case of the 100 KC trigger rate it may not be possible to obtain a single trace. It should, however, be possible to

reduce the display to a double trace. Very slight adjustment of the 5 μ S pot will often help minimize trigger pull on the 10 μ S range.

6. Adjustment of the Crystal Oscillator

Accuracy of the time markers in the Type 180A depends upon the precise adjustment of the frequency of the 1 MC crystal oscillator. Variable capacitor, C105 permits exact setting of the frequency of the crystal oscillator.

Precise adjustment of the crystal frequency can be accomplished by beating or 'heterodyning' the crystal oscillator

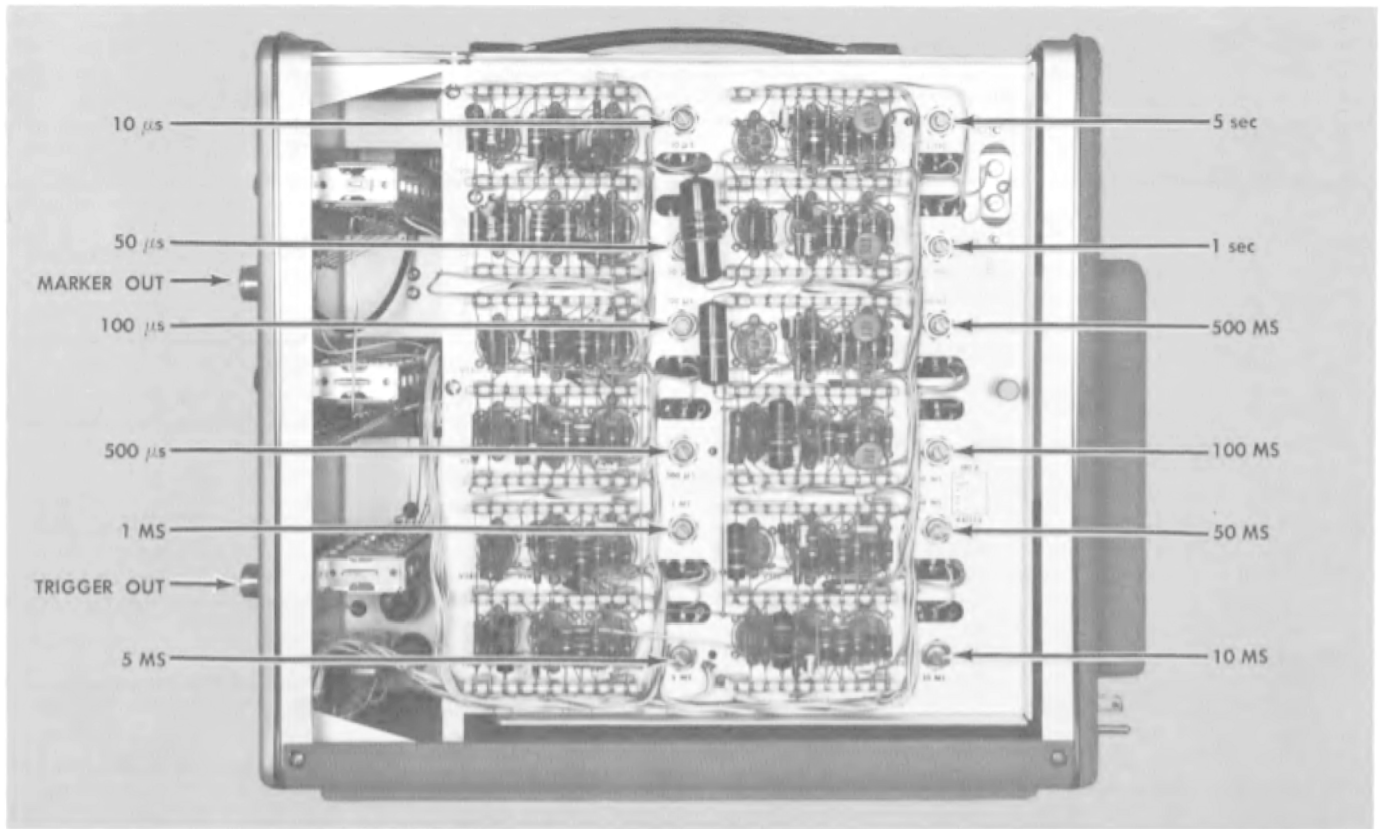

Fig. 5-4 Right side view showing calibration adjustments, S/N 5001 up.

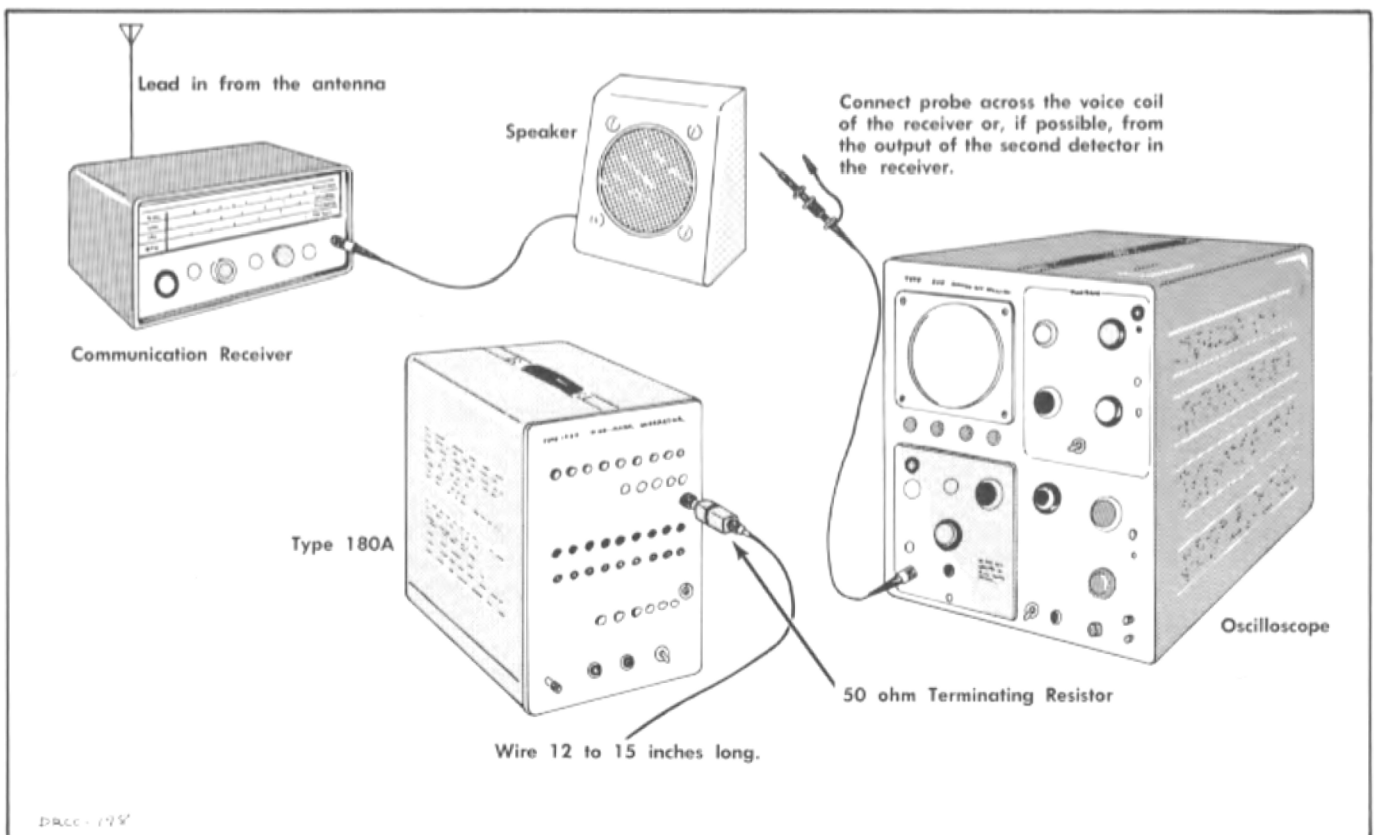

Fig. 5-5 Suggested instrument setup for adjusting crystal oscillator frequency, all serial numbers.

signal against a standard frequency signal as transmitted by WWV, the National Bureau of Standards. This station transmits continuously on frequencies of 5, 10, 15, and 20 MC. Use of a dependable communication receiver and an oscilloscope permits extreme accuracy of adjustment as both audio and visual checks are available. A suitable procedure for calibrating the crystal oscillator is as follows:

Connect the equipment as shown in Fig. 5-5. You will note that there is no direct electrical connection between the Type 180A and either the receiver or the oscilloscope. Before starting to calibrate the crystal oscillator, be sure the Type 180A has been turned on continuously for at least an hour so all the components as well as the crystal can stabilize.

Tuning of the crystal oscillator will be accomplished by beating a harmonic of the crystal oscillator against the frequency of WWV. Now tune the receiver to 5, 10, 15, or 20 MC, whichever is strongest. It is best to use the higher frequencies if possible, as greater accuracy can be attained. The signal of WWV can be recognized first by the clicks which occur once each second. For a portion of each minute, a 440 cycle tone is also heard. During the time the tone is being heard is a good time to adjust the vertical sensitivity of the oscilloscope to about 4 CM of deflection. Now turn on the CW or Beat Note Oscillator in the receiver. Tune the receiver carefully so only the 440 cycle tone can be heard. Turn off the CW oscillator. Now install a 50 ohm terminating resistor on the MARKER OUT terminal of the Type 180A and insert a short (12 or 15 inch) piece of wire in the center of the terminator. Press the Red button to release any buttons on the 180A

which might have been depressed. Now press the 1 μ sec button. The short wire will act as a radiator for the 1 MC signal and will be picked up by the receiver. If the signal is too strong from the 180A, it may block out the signal from WWV. If this occurs, shorten the radiating wire until WWV can again be heard. If the frequency of the crystal oscillator is several cycles off you may hear a tone in the receiver, even when the tone from WWV stops.

Set the sweep rate of the oscilloscope for 2 Milliseconds/CM. Now wait for WWV to stop the tone transmission. Using an insulated aligning screwdriver, turn C105 through its range and you will note that one point will be found where the tone decreases in pitch and then rises as a center point is reached and passed. The deflection on the oscilloscope will also drop to a straight line as this center point is reached. Adjust C105 to this center point. If you have the receiver tuned to 10 MC or higher, the crystal is sure to be within ± 10 cycles of 1 MC. For example, if you have the receiver tuned to 15 MC, you will be comparing the 15th harmonic of the crystal oscillator to the frequency of WWV and a 1 cycle error in the crystal oscillator will show up as a 15 cycle error on the oscilloscope.

After the crystal frequency has been adjusted, do not disturb any of the components in the oscillator circuit. If V100 or any other component in the oscillator is changed, the frequency of the crystal oscillator should be checked. This adjustment of C105 will not effect the other markers as they are timed by this basic frequency and will follow small changes.

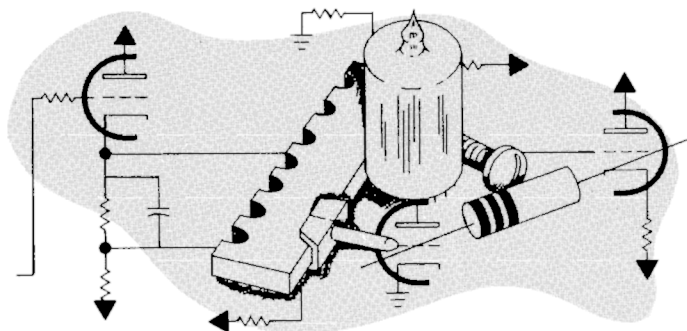

SECTION 6

PARTS LIST AND SCHEMATICS

ABBREVIATIONS

Cer.	Ceramic	p	Pico, or 10^{-12}
Comp.	Composition	PMC	Paper, metal cased
EMC	Electrolytic, metal cased	Poly.	Polystyrene
EMT	Electrolytic, metal tubular	Prec.	Precision
f	Farad	PT	Paper, tubular
F & I	Focus and Intensity	PTM	Paper, tubular, moulded
G	Giga, or 10^9	S/N	Serial number
GMV	Guaranteed minimum value	T	Turns
h	Henry	TD	Toroid
K or k	Kilohms, or kilo (10^3)	Tub.	Tubular
M or meg	Megohms, or mega (10^6)	v	Working volts DC
μ	Micro, or 10^{-6}	Var.	Variable
m	Milli, or 10^{-3}	w	Watt
n	Nano, or 10^{-9}	w/	With
Ω	Ohm	WW	Wire-wound

SPECIAL NOTES AND SYMBOLS

X000 Part first added at this serial number.

000X Part removed after this serial number.

*000-000 Asterisk preceding Tektronix Part Number indicates manufactured by or for Tektronix, also reworked or checked components.

Use 000-000 Part number indicated is direct replacement.

HOW TO ORDER PARTS

Replacement parts are available from or through your local Tektronix Field Office.

Changes to Tektronix instruments are sometimes made to accommodate improved components as they become available, and to give you the benefit of the latest circuit improvements developed in our engineering department. It is therefore important, when ordering parts, to include the following information in your order: Part number including any suffix, instrument type, serial number, and modification number if applicable.

If a part you have ordered has been replaced with a new or improved part, your local Field Office will contact you concerning any change in part number.

ELECTRICAL PARTS LIST

Values are fixed unless named variable.

Ckt. No.	Tektronix Part No.	Description	S/N Range
----------	--------------------	-------------	-----------

Bulbs

B101	150-001	Incandescent #47 Crystal Oven	
B701	150-001	Incandescent #47 Pilot Light	
	158-007	Crystal Oven Assembly	

Capacitors

Tolerance $\pm 20\%$ unless otherwise indicated.

Tolerance of all electrolytic capacitors are as follows: (with exceptions)

3 V — 50 V = -10% , $+250\%$

51 V — 350 V = -10% , $+100\%$

351 V — 450 V = -10% , $+50\%$

C100	283-002	.01 μf	Disc. Type	500 v		X5499-up
C101	283-000	.001 μf	Disc. Type	500 v		
C103	281-518	47 pf	Cer.	500 v		
C104	281-501	4.7 pf	Cer.	500 v	± 1 pf	
C105	281-010	4.5-25 pf	Cer.		Var.	
C110	281-518	47 pf	Cer.	500 v		
C112	Use 283-002	.01 μf	Disc. Type	500 v		
C114	283-000	.001 μf	Disc. Type	500 v		
C116	281-503	8 pf	Cer.	500 v	$\pm .5$ pf	5001-5478
	281-009	3-12 pf	Cer.		Var.	5479-up
C120	283-000	.001 μf	Disc. Type	500 v		
C121	283-000	.001 μf	Disc. Type	500 v		
C122	281-509	15 pf	Cer.	500 v	10%	5001-5478
	281-518	47 pf	Cer.	500 v		5479-up
C123	281-012	7-45 pf	Cer.		Var.	
C124	281-508	12 pf	Cer.	500 v	$\pm .6$ pf	
C126	283-000	.001 μf	Disc. Type	500 v		
C127	Use 281-511	22 pf	Cer.	500 v	10%	
C129	281-012	7-45 pf	Cer.		Var.	
C130	283-000	.001 μf	Disc. Type	500 v		
C131	283-000	.001 μf	Disc. Type	500 v		
C133	281-007	3-12 pf	Cer.		Var.	
C134	281-508	12 pf	Cer.	500 v	$\pm .6$ pf	
C136	283-000	.001 μf	Disc. Type	500 v		
C137	281-508	12 pf	Cer.	500 v	$\pm .6$ pf	
C139	281-007	3-12 pf	Cer.		Var.	
C140	283-000	.001 μf	Disc. Type	500 v		
C141	283-000	.001 μf	Disc. Type	500 v		
C143	281-007	3-12 pf	Cer.		Var.	
C147	281-007	3-12 pf	Cer.		Var.	

Parts List — Type 180A

Capacitors (continued)

Ckt. No.	Tektronix Part No.		Description			S/N Range
C163	283-000	.001 μ f	Disc. Type	500 v		
C167	281-542	18 pf	Cer.	500 v	10%	
C177	281-509	15 pf	Cer.	500 v	10%	
C181	283-002	.01 μ f	Disc. Type	500 v		
C207	281-511	22 pf	Cer.	500 v	10%	
C217	281-509	15 pf	Cer.	500 v	10%	
C222	281-518	47 pf	Cer.	500 v		
C227	281-519	47 pf	Cer.	500 v	10%	
C237	281-513	27 pf	Cer.	500 v		5001-5478
	281-518	47 pf	Cer.	500 v		5479-up
C242	281-542	18 pf	Cer.	500 v	10%	
C247	Use 283-503	56 pf	Mica	500 v	10%	
C257	281-516	39 pf	Cer.	500 v	10%	5001-5478
	281-549	68 pf	Cer.	500 v	10%	5479-up
C262	281-518	47 pf	Cer.	500 v		
C267	283-543	250 pf	Mica	500 v	5%	
C277	281-509	15 pf	Cer.	500 v	10%	5001-5478
	281-524	150 pf	Cer.	500 v		5479-up
C282	281-518	47 pf	Cer.	500 v		
C287	283-545	390 pf	Mica	500 v	5%	5001-6019
	283-543	250 pf	Mica	500 v	5%	6020-up
C297	281-524	150 pf	Cer.	500 v		5001-5478
	281-525	470 pf	Cer.	500 v		5479-up
C302	281-518	47 pf	Cer.	500 v		
C307	285-543	.0022 μ f	MT	400 v		
C317	281-546	330 pf	Cer.	500 v	10%	5001-5478
	281-536	1000 pf	Cer.	500 v	10%	5479-up
C322	281-518	47 pf	Cer.	500 v		
C327	285-546	330 pf	MT	400 v		
C337	281-525	470 pf	Cer.	500 v		5001-5478
	281-536	1000 pf	Cer.	500 v	10%	5479-up
C342	281-518	47 pf	Cer.	500 v		
C347	285-510	.01 μ f	MT	400 v		
C356	281-536	1000 pf	Cer.	500 v	10%	X5479-up
C357	281-525	470 pf	Cer.	500 v		5001-5478
	281-536	1000 pf	Cer.	500 v	10%	5479-up
C362	281-518	47 pf	Cer.	500 v		
C367	285-552	.018 μ f	MT	600 v		
C377	281-536	1000 pf	Cer.	500 v	10%	5001-5478
	283-001	.005 μ f	Disc. Type	500 v		5479-up
C382	281-518	47 pf	Cer.	500 v		
C387	285-526	.1 μ f	MT	400 v		
C397	281-536	1000 pf	Cer.	500 v	10%	5001-5478
	283-001	.005 μ f	Disc. Type	500 v		5479-up
C402	281-518	47 pf	Cer.	500 v		
C407	285-533	.22 μ f	MT	400 v		
C417	281-536	1000 pf	Cer.	500 v	10%	5001-5478
	283-001	.005 μ f	Disc. Type	500 v		5479-up

Capacitors (continued)

Ckt. No.	Tektronix Part No.	Description			S/N Range
C422	281-518	47 pf	Cer.	500 v	
C427	285-553	1 μ f	PMC	600 v	
C437	281-536	1000 pf	Cer.	500 v	10% 5001-5478
	283-001	.005 μ f	Disc. Type	500 v	5479-up
C503	281-501	4.7 pf	Cer.	500 v	\pm 1 pf
C505	281-506	12 pf	Cer.	500 v	10%
C553	281-536	1000 pf	Cer.	500 v	10%
C560	283-000	.001 μ f	Disc. Type	500 v	5001-5478
	283-008	.1 μ f	Disc. Type	500 v	5479-up
C701	290-036	2 x 20 μ f	EMC	450 v	
C712	285-510	.01 μ f	MT	400 v	
C715A,B	290-037	2 x 20 μ f	EMC	450 v	
C721	290-043	2 x 40 μ f	EMC	450 v	
C736	285-510	.01 μ f	MT	400 v	
C741	290-044	125 μ f	EMC	350 v	
C744	285-510	.01 μ f	MT	400 v	
C761	285-510	.01 μ f	MT	400 v	
C763	290-083	3 x 10 μ f	EMC	350 v	
C770	290-025	6.25 μ f	EMT	300 v	
C774	285-510	.01 μ f	MT	400 v	

Diodes

D562	152-008	Germanium, T12G		
D702A,B,C,D	152-047	Silicon 1N2862 (or equal)		X6386-up
D722A,B,C,D	152-047	Silicon 1N2862 (or equal)		X6386-up
D742A,B,C,D	152-047	Silicon 1N2862 (or equal)		X6386-up

Fuses

F701	159-026	3.2 amp, 3AG Slo-Blo 117 v operation, 50-60 cycle		
	159-003	1.6 amp, 3AG Slo-Blo 234 v operation, 50-60 cycle		
F702	159-028	.25 amp, 3AG Fast-Blo 117 v and 234 v operation, 50-60 cycle		

Inductors

L101	*108-065	1.1 mh		
L107	*108-068	600 μ h		5001-5478
	*108-065	1.1 mh		5479-up
LR116	*108-156	300 μ h	(on 10 k, 1 w, resistor)	X5479-up
L124	*108-011	18 μ h		
L127	*108-142	16 μ h		
L134	*108-023	9.2 μ h		
L137	*108-023	9.2 μ h		
L144	*108-003	1.1 μ h		
L147	*108-003	1.1 μ h		

Parts List — Type 180A

Inductors (continued)

Ckt. No.	Tektronix Part No.	Description	S/N Range
LR171	*108-068	600 μ h (on 3.3 k, 1 w, resistor)	5001-5478
	*108-155	1 mh (on 10 k, 1 w, resistor)	5479-up
L177	*108-065	1.1 mh	X5479-up
LR211	*108-068	600 μ h (on 3.3 k, 1 w, resistor)	5001-5479
	*108-155	1 mh (on 10 k, 1 w, resistor)	5479-up
LR231	*108-068	600 μ h (on 3.3 k, 1 w, resistor)	5001-5478
	*108-155	1 mh (on 10 k, 1 w, resistor)	5479-up

Rectifiers †

SR701	*106-005	4 plates/leg	5001-6385X
SR721A,B	*106-049	8 plates/leg	5001-6385X
SR741	*106-005	4 plates/leg	5001-6385X

Resistors

Resistors are fixed, composition, $\pm 10\%$ unless otherwise indicated.

R101	302-563	56 k	$\frac{1}{2}$ w	
R102	302-182	1.8 k	$\frac{1}{2}$ w	
R103	302-392	3.9 k	$\frac{1}{2}$ w	
R105	302-563	56 k	$\frac{1}{2}$ w	
R108	302-562	5.6 k	$\frac{1}{2}$ w	5001-5478
	302-332	3.3 k	$\frac{1}{2}$ w	5479-up
R110	302-224	220 k	$\frac{1}{2}$ w	
R112	302-473	47 k	$\frac{1}{2}$ w	
R114	302-393	39 k	$\frac{1}{2}$ w	
R115	301-224	220 k	$\frac{1}{2}$ w	5% 5001-5478
	301-104	100 k	$\frac{1}{2}$ w	5% 5479-up
R116	302-682	6.8 k	$\frac{1}{2}$ w	5001-5478
	302-103	10 k	$\frac{1}{2}$ w	5479-up
R117	302-101	100 Ω	$\frac{1}{2}$ w	
R118	302-221	220 Ω	$\frac{1}{2}$ w	5001-5478
	302-102	1 k	$\frac{1}{2}$ w	5479-up
R120	302-473	47 k	$\frac{1}{2}$ w	
R122	302-822	8.2 k	$\frac{1}{2}$ w	
R126	302-473	47 k	$\frac{1}{2}$ w	5001-5478
	302-224	220 k	$\frac{1}{2}$ w	5479-up
R128	302-220	22 Ω	$\frac{1}{2}$ w	
R130	302-473	47 k	$\frac{1}{2}$ w	
R136	302-473	47 k	$\frac{1}{2}$ w	5001-5478
	302-224	220 k	$\frac{1}{2}$ w	5479-up
R138	302-220	22 Ω	$\frac{1}{2}$ w	
R140	302-473	47 k	$\frac{1}{2}$ w	

† S/N 6386-up see D702, D722, D742.

A kit is available to convert from Selenium Rectifiers to Silicon Diodes. Order Mod Kit #040-214.

Resistors (Cont'd.)

Ckt. No.	Tektronix Part No.		Description			S/N Range
R154	302-101	100 Ω	$\frac{1}{2}$ w			
R155	304-333	33 k	1 w			5001-5478
	306-273	27 k	2 w			5479-up
R161	305-682	6.8 k	2 w		5%	
R163	302-102	1 k	$\frac{1}{2}$ w			
R164	302-101	100 Ω	$\frac{1}{2}$ w			
R165	305-153	15 k	2 w		5%	
R167	309-017	1.5 meg	$\frac{1}{2}$ w		1%	
R168	311-039	1 meg	2 w	Var.	Prec.	5 μ SEC
R170	302-101	100 Ω	$\frac{1}{2}$ w			
R172	302-562	5.6 k	$\frac{1}{2}$ w			
R174	302-101	100 Ω	$\frac{1}{2}$ w			
R175	306-333	33 k	2 w			
R177	302-183	18 k	$\frac{1}{2}$ w			
R178	302-221	220 Ω	$\frac{1}{2}$ w			5001-5478
	302-272	2.7 k	$\frac{1}{2}$ w			5479-up
R181	302-181	180 Ω	$\frac{1}{2}$ w			
R201	305-822	8.2 k	2 w		5%	
R204	302-101	100 Ω	$\frac{1}{2}$ w			
R205	305-183	18 k	2 w		5%	5001-5478
	305-153	15 k	2 w		5%	5479-up
R207	309-017	1.5 meg	$\frac{1}{2}$ w		Prec.	1%
	309-014	1 meg	$\frac{1}{2}$ w		Prec.	1%
R208	311-044	5 meg	2 w	Var.		10 μ SEC
R210	302-101	100 Ω	$\frac{1}{2}$ w			
R211	302-822	8.2 k	$\frac{1}{2}$ w			
R214	302-101	100 Ω	$\frac{1}{2}$ w			
R215	306-333	33 k	2 w			
R217	302-183	18 k	$\frac{1}{2}$ w			
R218	302-221	220 Ω	$\frac{1}{2}$ w			5001-5478
	302-272	2.7 k	$\frac{1}{2}$ w			5479-up
R221	303-123	12 k	1 w		5%	5001-5478
	303-822	8.2 k	1 w		5%	5479-up
R222	303-153	15 k	1 w		5%	5001-5478
	303-103	10 k	1 w		5%	5479-up
R224	302-101	100 Ω	$\frac{1}{2}$ w			
R225	305-273	27 k	2 w		5%	5001-5478
	305-223	22 k	2 w		5%	5479-up
R227	309-023	2 meg	$\frac{1}{2}$ w		1%	
R228	311-042	2 meg	2 w	Var.	Prec.	50 μ SEC
R230	302-101	100 Ω	$\frac{1}{2}$ w			
R231	302-153	15 k	$\frac{1}{2}$ w			
R234	302-101	100 Ω	$\frac{1}{2}$ w			
R235	306-333	33 k	2 w			
R237	302-183	18 k	$\frac{1}{2}$ w			
R238	302-221	220 Ω	$\frac{1}{2}$ w			5001-5478
	302-272	2.7 k	$\frac{1}{2}$ w			5479-up

Parts List — Type 180A

Resistors (continued)

Ckt. No.	Tektronix Part No.		Description			S/N Range
R241	301-103	10 k	1/2 w		5%	
R242	301-183	18 k	1/2 w		5%	
R244	302-101	100 Ω	1/2 w			
R245	305-393	39 k	2 w		5%	5001-5478
	305-273	27 k	2 w		5%	5479-up
R247	309-026	3 meg	1/2 w		Prec.	5001-5478
	309-023	2 meg	1/2 w		Prec.	5479-up
R248	311-044	5 meg	2 w	Var.	100 μSEC	
R250	302-101	100 Ω	1/2 w			
R251	302-183	18 k	1/2 w			5001-5478
	302-223	22 k	1/2 w			5479-up
R254	302-101	100 Ω	1/2 w			
R255	304-473	47 k	1 w			
R257	302-223	22 k	1/2 w			
R258	302-221	220 Ω	1/2 w			5001-5478
	302-272	2.7 k	1/2 w			5479-up
R261	301-123	12 k	1/2 w		5%	
R262	301-183	18 k	1/2 w		5%	
R264	302-101	100 Ω	1/2 w			
R265	305-393	39 k	2 w		5%	
R267	309-087	5 meg	1/2 w		Prec.	1%
R268	311-042	2 meg	2 w	Var.	500 μSEC	
R270	302-101	100 Ω	1/2 w			
R271	302-333	33 k	1/2 w			5001-5478
	302-273	27 k	1/2 w			5479-6019
	302-333	33 k	1/2 w			6020-up
R274	302-101	100 Ω	1/2 w			
R275	304-473	47 k	1 w			
R277	302-223	22 k	1/2 w			
R278	302-221	220 Ω	1/2 w			5001-5478
	302-272	2.7 k	1/2 w			5479-up
R281	301-183	18 k	1/2 w		5%	
R282	301-223	22 k	1/2 w		5%	
R284	302-101	100 Ω	1/2 w			
R285	305-473	47 k	2 w		5%	
R287	309-087	5 meg	1/2 w		Prec.	1%
R288	311-044	5 meg	2 w	Var.	1 mSEC	
R290	302-101	100 Ω	1/2 w			
R291	302-393	39 k	1/2 w			
R294	302-101	100 Ω	1/2 w			
R295	304-473	47 k	1 w			
R297	302-223	22 k	1/2 w			
R298	302-221	220 Ω	1/2 w			5001-5478
	302-272	2.7 k	1/2 w			5479-up
R301	301-183	18 k	1/2 w		5%	
R302	301-223	22 k	1/2 w		5%	

Resistors (continued)

Ckt. No.	Tektronix Part No.		Description			S/N Range
R304	302-101	100 Ω	$\frac{1}{2}$ w			
R305	305-473	47 k	2 w			5%
R307	Use 309-093	4 meg	$\frac{1}{2}$ w		Prec.	1%
R308	311-044	5 meg	2 w	Var.		5 mSEC
R310	302-101	100 Ω	$\frac{1}{2}$ w			
R311	302-393	39 k	$\frac{1}{2}$ w			
R314	302-101	100 Ω	$\frac{1}{2}$ w			
R315	304-473	47 k	1 w			
R317	302-223	22 k	$\frac{1}{2}$ w			
R318	302-221	220 Ω	$\frac{1}{2}$ w			5001-5478
	302-272	2.7 k	$\frac{1}{2}$ w			5479-up
R321	301-183	18 k	$\frac{1}{2}$ w			5%
R322	301-223	22 k	$\frac{1}{2}$ w			5%
R324	302-101	100 Ω	$\frac{1}{2}$ w			
R325	305-473	47 k	2 w			5%
R327	309-087	5 meg	$\frac{1}{2}$ w		Prec.	1%
R328	311-044	5 meg	2 w	Var.		10 mSEC
R330	302-101	100 Ω	$\frac{1}{2}$ w			
R331	302-393	39 k	$\frac{1}{2}$ w			
R334	302-101	100 Ω	$\frac{1}{2}$ w			
R335	304-473	47 k	1 w			
R337	302-223	22 k	$\frac{1}{2}$ w			
R338	302-221	220 Ω	$\frac{1}{2}$ w			5001-5478
	302-272	2.7 k	$\frac{1}{2}$ w			5479-up
R341	301-183	18 k	$\frac{1}{2}$ w			5%
R342	301-223	22 k	$\frac{1}{2}$ w			5%
R344	302-101	100 Ω	$\frac{1}{2}$ w			
R345	305-473	47 k	2 w			5%
R347	309-095	10 meg	$\frac{1}{2}$ w		Prec.	1%
R348	311-044	5 meg	2 w	Var.		50 mSEC
R350	302-101	100 Ω	$\frac{1}{2}$ w			
R351	302-393	39 k	$\frac{1}{2}$ w			
R354	302-101	100 Ω	$\frac{1}{2}$ w			
R355	304-473	47 k	1 w			
R357	302-223	22 k	$\frac{1}{2}$ w			
R358	302-221	220 Ω	$\frac{1}{2}$ w			5001-5478
	302-272	2.7 k	$\frac{1}{2}$ w			5479-up
R361	301-333	33 k	$\frac{1}{2}$ w			5%
R362	301-473	47 k	$\frac{1}{2}$ w			5%
R364	302-101	100 Ω	$\frac{1}{2}$ w			
R365	303-104	100 k	1 w			5%
R367	310-061	15 meg	1 w		Prec.	2%
	310-069	13 meg	1 w		Prec.	2%
R368	311-044	5 meg	2 w	Var.		100 mSEC
R370	302-101	100 Ω	$\frac{1}{2}$ w			
R371	302-393	39 k	$\frac{1}{2}$ w			
R374	302-101	100 Ω	$\frac{1}{2}$ w			
R375	304-154	150 k	1 w			

Parts List — Type 180A

Resistors (continued)

Ckt. No.	Tektronix Part No.		Description			S/N Range
R377	302-154	150 k	1/2 w			
R378	302-221	220 Ω	1/2 w			5001-5478
	302-272	2.7 k	1/2 w			5479-up
R381	301-333	33 k	1/2 w		5%	
R382	301-473	47 k	1/2 w		5%	
R384	302-101	100 Ω	1/2 w			
R385	303-104	100 k	1 w		5%	
R387	Use 310-108	11.66 meg	1 w		1%	
R388	311-044	5 meg	2 w	Var.	Prec.	500 mSEC
R390	302-101	100 Ω	1/2 w			
R391	302-563	56 k	1/2 w			5001-5478
	302-393	39 k	1/2 w			5479-up
R394	302-101	100 Ω	1/2 w			
R395	304-154	150 k	1 w			
R397	302-154	150 k	1/2 w			
R398	302-221	220 Ω	1/2 w			5001-5478
	302-272	2.7 k	1/2 w			5479-up
R401	301-333	33 k	1/2 w		5%	
R402	301-473	47 k	1/2 w		5%	
R404	302-101	100 Ω	1/2 w			
R405	303-104	100 k	1 w		5%	
R407	309-095	10 meg	1/2 w		1%	
R408	311-044	5 meg	2 w	Var.	Prec.	1 SEC
R410	302-101	100 Ω	1/2 w			
R411	302-563	56 k	1/2 w			5001-5478
	302-473	47 k	1/2 w			5479-up
R414	302-101	100 Ω	1/2 w			
R415	304-154	150 k	1 w			
R417	302-154	150 k	1/2 w			
R418	302-221	220 Ω	1/2 w			5001-5478
	302-272	2.7 k	1/2 w			5479-up
R421	301-333	33 k	1/2 w		5%	
R422	301-473	47 k	1/2 w		5%	
R424	302-101	100 Ω	1/2 w			
R425	303-104	100 k	1 w		5%	
R427	309-095	10 meg	1/2 w		Prec.	1%
R428	311-044	5 meg	2 w	Var.		5 SEC
R430	302-101	100 Ω	1/2 w			
R431	302-563	56 k	1/2 w			5001-5478
	302-473	47 k	1/2 w			5479-up
R437	302-154	150 k	1/2 w			
R438	302-221	220 Ω	1/2 w			5001-5478
	302-272	2.7 k	1/2 w			5479-up
R501	302-471	470 Ω	1/2 w			
R503	302-182	1.8 k	1/2 w			
R505	302-182	1.8 k	1/2 w			

Resistors (continued)

Ckt. No.	Tektronix Part No.		Description			S/N Range
R507	302-182	1.8 k	1/2 w			
R509	302-182	1.8 k	1/2 w			
R511	302-182	1.8 k	1/2 w			
R513	302-182	1.8 k	1/2 w			
R515	302-182	1.8 k	1/2 w			
R517	302-182	1.8 k	1/2 w			
R519	302-182	1.8 k	1/2 w			
R521	302-182	1.8 k	1/2 w			
R523	302-182	1.8 k	1/2 w			
R525	302-182	1.8 k	1/2 w			
R527	302-182	1.8 k	1/2 w			
R529	302-182	1.8 k	1/2 w			
R530	302-101	100 Ω	1/2 w			
R531	302-101	100 Ω	1/2 w			
R532	302-101	100 Ω	1/2 w			
R550	302-224	220 k	1/2 w			
R551	302-101	100 Ω	1/2 w			
R553	302-471	470 Ω	1/2 w			
R560	301-332	3.3 k	1/2 w		5%	
R561	302-683	68 k	1/2 w			5001-5478
	302-154	150 k	1/2 w			5479-up
R565	302-104	100 k	1/2 w			
R567	302-101	100 Ω	1/2 w			
R569	302-221	220 Ω	1/2 w			
R701	302-100	10 Ω	1/2 w			X6386-up
R703	306-154	150 k	2 w			
R704	302-273	27 k	1/2 w			
R707	302-104	100 k	1/2 w			
R708	302-185	1.8 meg	1/2 w			
R712	309-011	780 k	1/2 w	Prec.	1%	5001-5231
	Use 310-124	237 k	1 w	Prec.		5232-up
R713	309-053	333 k	1/2 w	Prec.	1%	5001-5231
	Use 309-334	100 k	1/2 w	Prec.	1%	5232-up
R720	Use 304-100	10 Ω	1 w			X6386-up
R721	302-274	270 k	1/2 w			
R722	302-563	56 k	1/2 w			
R724	302-155	1.5 meg	1/2 w			
R726	302-185	1.8 meg	1/2 w			
R735	302-225	2.2 meg	1/2 w			
R736	309-052	220 k	1/2 w	Prec.	1%	
R737	309-092	143 k	1/2 w	Prec.	1%	
R738	308-017	2 k	10 w	WW	5%	X5599-6385
	308-018	2.5 k	10 w	WW	5%	6386-up
R741	302-100	10 Ω	1/2 w			X6386-up
R742	309-042	68 k	1/2 w	Prec.	1%	
R743	311-015	10 k	2 w	Var.	WW	—150 v ADJ.

Parts List — Type 180A

Resistors (continued)

Ckt. No.	Tektronix Part No.	Description	Prec.	S/N Range
R744	309-090	50 k	1/2 w	1%
R746	302-105	1 meg	1/2 w	
R750	302-183	18 k	1/2 w	
R754	302-155	1.5 meg	1/2 w	
R758	302-102	1 k	1/2 w	
R762	302-333	33 k	1/2 w	5%
R770	302-393	39 k	1/2 w	
R772	302-274	270 k	1/2 w	
R774	301-682	6.8 k	1/2 w	
R776	301-124	120 k	1/2 w	
R780	301-393	39 k	1/2 w	5%
R781	301-204	200 k	1/2 w	
R782	302-101	100 Ω	1/2 w	
R784	306-153	15 k	2 w	

Switches

Unwired

SW510	260-191	Pushbutton, HIGH FREQUENCY
SW520	260-192	Pushbutton, LOW FREQUENCY
SW550	260-193	Pushbutton, TRIGGER SELECTOR
SW701	260-134	Toggle, POWER ON
TK701	260-120	Thermal Cut-Out 137° F

Transformers

T701	*050-004	L.V. Power	5001-5598
	*120-119	L.V. Power	
T702	*120-052	Crystal Oven Power	5599-up

Electron Tubes

V100	154-078	6AN8
V104	154-078	6AN8
V124	154-367	6DK6/8136
V134	154-367	6DK6/8136
V144	154-367	6DK6/8136
V162	154-016	6AL5
V165	154-147	5965
V173	154-041	12AU7
V202	154-016	6AL5
V205	154-147	5965
V213	154-041	12AU7
V222	154-016	6AL5
V225	154-147	5965
V233	154-041	12AU7
V242	154-016	6AL5

Electron Tubes (continued)

Ckt. No.	Tektronix Part No.	Description	S/N Range
V245	154-147	5965	
V253	154-041	12AU7	
V262	154-016	6AL5	
V265	154-147	5965	
V273	154-041	12AU7	
V282	154-016	6AL5	
V285	154-147	5965	
V293	154-041	12AU7	
V302	154-016	6AL5	
V305	154-147	5965	
V313	154-041	12AU7	
V322	154-016	6AL5	
V325	154-147	5965	
V333	154-041	12AU7	
V342	154-016	6AL5	
V345	154-147	5965	
V353	154-041	12AU7	
V362	154-016	6AL5	
V365	154-147	5965	
V373	154-041	12AU7	
V382	154-016	6AL5	
V385	154-147	5965	
V393	154-041	12AU7	
V402	154-016	6AL5	
V405	154-147	5965	
V413	154-041	12AU7	
V422	154-016	6AL5	
V425	154-147	5965	
V433	154-041	12AU7	
V553	154-147	5965	
V704	154-022	6AU6	
V707	154-056	6080	
V724	154-022	6AU6	
V744	154-078	6AN8	
V749	154-052	5651	
V757	154-044	12B4	
V767	154-044	12B4	

Mechanical Parts List

	Tektronix Part Number
Adapter, 3 wire to 2 wire S/N 5552-up	103-013
Angle, frame bottom S/N 5001-6617	122-044
Angle, frame bottom, blue vinyl S/N 6618-up	122-062
Bar, $\frac{3}{16} \times \frac{1}{2} \times 1$ w/6-32 holes	381-084
Bar, $.125 \times 1\frac{9}{32} \times 3\frac{7}{8}$ switch cancelling	381-090
Bar, ext. top support w/handles S/N 9773-up	Use 381-232
Bolt, captive	214-008
Bolt, Spade steel 6-32 x $\frac{3}{8}$	214-012
Bracket, 3 x 3 x $\frac{3}{4}$ lower support	406-305
Bracket, 1 x $1\frac{1}{8} \times \frac{1}{2}$ stop S/N 5001-5315	406-307
Bracket, $1\frac{9}{16} \times 4 \times 1\frac{1}{16}$ chassis stop S/N 5316-6179	406-405
Bracket, $1\frac{9}{16} \times 4 \times 1\frac{5}{32}$ chassis stop S/N 6180-up	406-511
Bracket, $\frac{1}{2} \times 1\frac{3}{16} \times 4\frac{1}{8}$ (4L bends) S/N 5001-5315	406-308
Bracket, $1\frac{5}{16} \times 2\frac{1}{16} \times \frac{3}{4}$ cancelling bar S/N 5316-up	406-406
Bracket, $3\frac{1}{2} \times 4\frac{5}{8} \times 3\frac{3}{8}$ lower hinge S/N 5001-5478	406-309
Bracket, $2\frac{5}{8} \times 3\frac{3}{8} \times \frac{3}{4}$ upper hinge S/N 5001-5315	406-310
Bracket, $1\frac{5}{16} \times 3\frac{3}{8} \times 1$ upper hinge S/N 5316-5478	406-404
Bracket, $1\frac{5}{16} \times 3\frac{3}{32} \times 1$ upper & lower hinge S/N 5479-up	406-411
Bracket, $3\frac{1}{2} \times 6\frac{3}{34}$ right back supp. S/N 5001-5478	406-440
Bracket, Transformer Mtg.	406-871
Bushing, nylon	358-042
Bushing, brass	358-049
Cable, harness power #1 S/N 5001-6385	179-183
Cable, harness power #1 S/N 6386-up	179-400
Cable, harness power #2	179-184
Cable, harness divider S/N 5001-5478	179-185
Cable, harness divider S/N 5479-up	179-280
Cable, harness 110 v S/N 5001-6385	179-216
Cable, harness 110 v S/N 6386-up	179-401
Cap, fuse	200-015
Cap, black push button	200-114
Cap, red push button	200-115

Mechanical Parts List (continued)

	Tektronix Part Number
Chassis, divider A	441-175
Chassis, power S/N 5001-6385	441-178
Chassis, power S/N 6386-up	441-307
Clamp, cable $\frac{5}{16}$ " plastic	343-004
Clamp, cable $\frac{5}{8}$ " plastic	343-007
Connector, chassis mount 2 cont. male S/N 5001-5551	131-010
Connector, chassis mount 3 wire male S/N 5552-up	131-102
Connector, chassis mount coax 1 cont. female S/N 5001-9409	131-081
Connector, chassis mount coax 1 cont. female BNC S/N 9410-up	131-126
Cord, power	161-010
Eyelet, tapered barrel	210-601
Filter, air 7 x 7 x 1	378-015
Grommet, rubber $\frac{1}{4}$	348-002
Grommet, rubber $\frac{5}{16}$	348-003
Grommet, rubber $\frac{1}{2}$	348-005
Grommet, rubber $\frac{5}{8}$	348-012
Holder, fuse 3 AG	352-010
Housing, air filter S/N 5001-6617	380-009
Housing, air filter S/N 6618-up	380-016
Jewel, pilot light green	378-513
Jewel, pilot light red	378-518
Lockwasher, ext. #6	210-005
Lockwasher, int. #6	210-006
Lockwasher, ext. #8	210-007
Lockwasher, int. #8	210-008
Lockwasher, pot int. $\frac{3}{8}$ x $\frac{1}{2}$	210-012
Lockwasher, int. $\frac{3}{8}$ x $\frac{11}{16}$	210-013
Lug, solder DE4	210-204
Lug, solder $\frac{1}{4}$ " lock round perimeter	210-223
Lug, solder for $\frac{1}{2}$ " stud	210-229
Mount, fan motor	426-052
Nut, hex 8-32 x $\frac{5}{16}$	210-402
Nut, captive alum.	210-403
Nut, hex 6-32 x $\frac{1}{4}$	210-407
Nut, hex 8-32 x $\frac{5}{16}$	210-409

Mechanical Parts List (continued)

	Part Number Tektronix
Nut, hex 10-32 x $\frac{5}{16}$	210-410
Nut, hex $\frac{3}{8}$ -32 x $\frac{1}{2}$	210-413
Nut, hex $\frac{15}{32}$ -32 x $\frac{9}{16}$	210-414
Nut, hex $\frac{1}{2}$ x $\frac{5}{8}$ with $\frac{3}{8}$ -32 int. thread	210-444
Nut, hex 10-32 x $\frac{3}{8}$ cad plated	210-445
Nut, keps 6-32 x $\frac{5}{16}$	210-457
Nut, keps 8-32 x $1\frac{1}{32}$	210-458
Nut, switch 12-sided	210-473
Nut, hex 6-32 x $\frac{5}{16}$ 5-10 res. mounting	210-478
Nut, hex 10-32 x $\frac{3}{8}$ x $\frac{1}{8}$	210-564
Panel, front "A"	333-325
Plate, sub-panel front "A"	386-683
Plate, sub-panel back "A"	386-681
Plate, back overlay S/N 5001-6617	386-682
Plate, back overlay S/N 6618-up	387-038
Plate, cab. bottom S/N 5001-5240	386-711
Plate, cab. bottom S/N 5241-6617	386-822
Plate, cab. bottom S/N 6618-up	387-037
Plate, cab. side L. & R. S/N 5001-6617	387-717
Plate, cab. side L. & R. S/N 6618-up	387-036
Post, connecting single $\frac{3}{32}$ S/N 5001-5779	129-007
Post, connecting ceramic 1" S/N 5001-5779	129-017
Post, binding ass'y (355-503 & 200-072)	129-020
Ring, securing S/N 5316-up	354-048
Ring, fan	354-063
Ring, retaining, truarc for $\frac{1}{4}$ " shaft	354-177
Rod, swivel $\frac{3}{8}$ x $\frac{3}{8}$ x $12\frac{1}{4}$ w/2 tapped 6-32 holes	384-537
Rod, $\frac{1}{2}$ x $\frac{31}{64}$ with $\frac{11}{64}$ hole	385-104
Rod, delrin $\frac{5}{16}$ x $2\frac{1}{4}$ mounting hole $\frac{3}{8}$ deep one end w/3 #44 cross holes	385-137
Rod, delrin $\frac{5}{16}$ x $1\frac{9}{16}$ mounting hole $\frac{3}{8}$ deep one end w/4 #44 cross holes	385-138
Screw, 4-40 x $\frac{3}{8}$ FHS	211-025
Screw, 4-40 x 1 FHS	211-031
Screw, 6-32 x $\frac{3}{16}$ BHS	211-503
Screw, 6-32 x $\frac{1}{4}$ BHS	211-504

Mechanical Parts List (continued)

	Tektronix Part Number
Screw, 6-32 x $\frac{5}{16}$ BHS	211-507
Screw, 6-32 x $\frac{3}{8}$ FHS	211-509
Screw, 6-32 x $\frac{3}{8}$ BHS	211-510
Screw, 6-32 x $\frac{5}{8}$ FHS, 100°	211-522
Screw, 6-32 x $\frac{5}{16}$ pan HS w/lockwasher	211-534
Screw, 6-32 x $\frac{3}{8}$ Truss HS	211-537
Screw, 6-32 x $\frac{5}{16}$ FHS, 100°, CSK, Phillips	211-538
Screw, 6-32 x $\frac{5}{16}$ RHS	211-543
Screw, 6-32 x 1 $\frac{1}{2}$ RHS, Phillips	211-553
Screw, 6-32 x $\frac{3}{8}$ FHS, 100°, CSK, Phillips	211-559
Screw, 8-32 x $\frac{5}{8}$ BHS	212-010
Screw, 8-32 x $\frac{3}{8}$ BHS	212-023
Screw, 8-32 x 1 $\frac{1}{4}$ RHS	212-031
Screw, 8-32 x $\frac{3}{8}$ FHS, 100°, Phillips	212-040
Screw, 8-32 x $\frac{5}{8}$ THS	212-072
Screw, 10-32 x $\frac{3}{8}$ BHS	212-507
Screw, 10-32 x $\frac{3}{8}$ HHS	212-531
Screw, thread cutting 6-32 x $\frac{3}{8}$ truss HS, Phillips	213-041
Screw, thread cutting 5-32 x $\frac{3}{16}$ pan HS, Phillips	213-044
Screw, thread forming #4 x $\frac{1}{4}$ Type B	213-088
Screw, thread forming 6-32 x $\frac{3}{8}$ THS	213-104
Shield, 1 $\frac{5}{8}$ x 1 $\frac{1}{4}$ x 1 $\frac{1}{16}$	337-188
Shield, 1 $\frac{3}{4}$ x 2 $\frac{1}{4}$ x 1 $\frac{1}{8}$	337-197
Shockmount, rubber $\frac{1}{2}$ x $\frac{1}{2}$	348-008
Socket, STM7G	136-008
Socket, STM8G	136-011
Socket, STM9G	136-015
Socket, light ass'y	136-025
Socket, banana jack	136-052
Spacer, nylon mld. $\frac{1}{16}$ for ceramic strips	S/N 5780-up 361-007
Spacer, nylon mld. $\frac{5}{16}$ for ceramic strips	S/N 5780-up 361-009
Spacer, socket, shield	361-011
Stop, steel	S/N 5001-5315 105-007
Strip, ceramic $\frac{3}{4}$ x 2 notches, clip mounted	124-086

Mechanical Parts List (continued)

	Tektronix Part Number
Strip, ceramic $\frac{3}{4} \times 7$ notches, clip mounted	124-089
Strip, ceramic $\frac{3}{4} \times 9$ notches, clip mounted	124-090
Strip, ceramic $\frac{3}{4} \times 11$ notches, clip mounted	124-091
Strip, ceramic $\frac{3}{4} \times 1$ notch, clip mounted	124-100
Tag, voltage rating	334-649
Washer, 6L x $\frac{3}{8}$ steel	210-803
Washer, 8S x $\frac{3}{8}$ steel	210-804
Washer, $\frac{1}{4} \times \frac{1}{2}$ alum.	210-821
Washer, .390 x $\frac{9}{16}$ steel	210-840
Washer, .164 x .500 nylon	210-847
Washer, rubber for fuse holder	210-873
Washer, .470 x $2\frac{1}{32}$	210-902
Washer, flat #14 brass	210-905
Washer, steel $\frac{1}{4} \times \frac{3}{8} \times .0206$	210-940

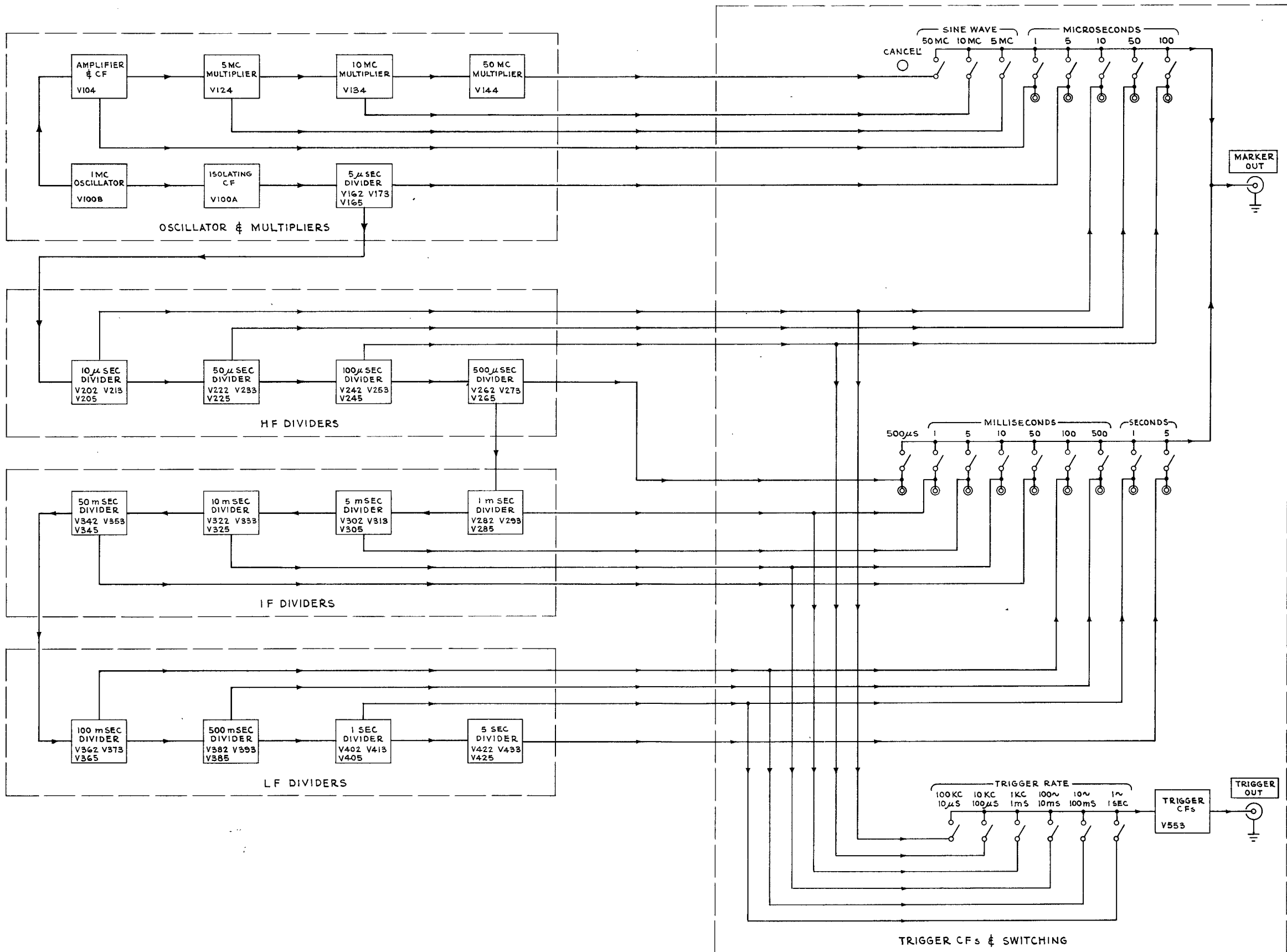

RBH 12-5-62

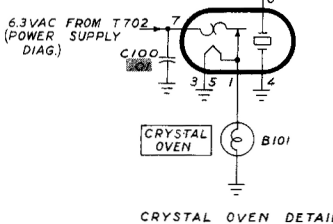
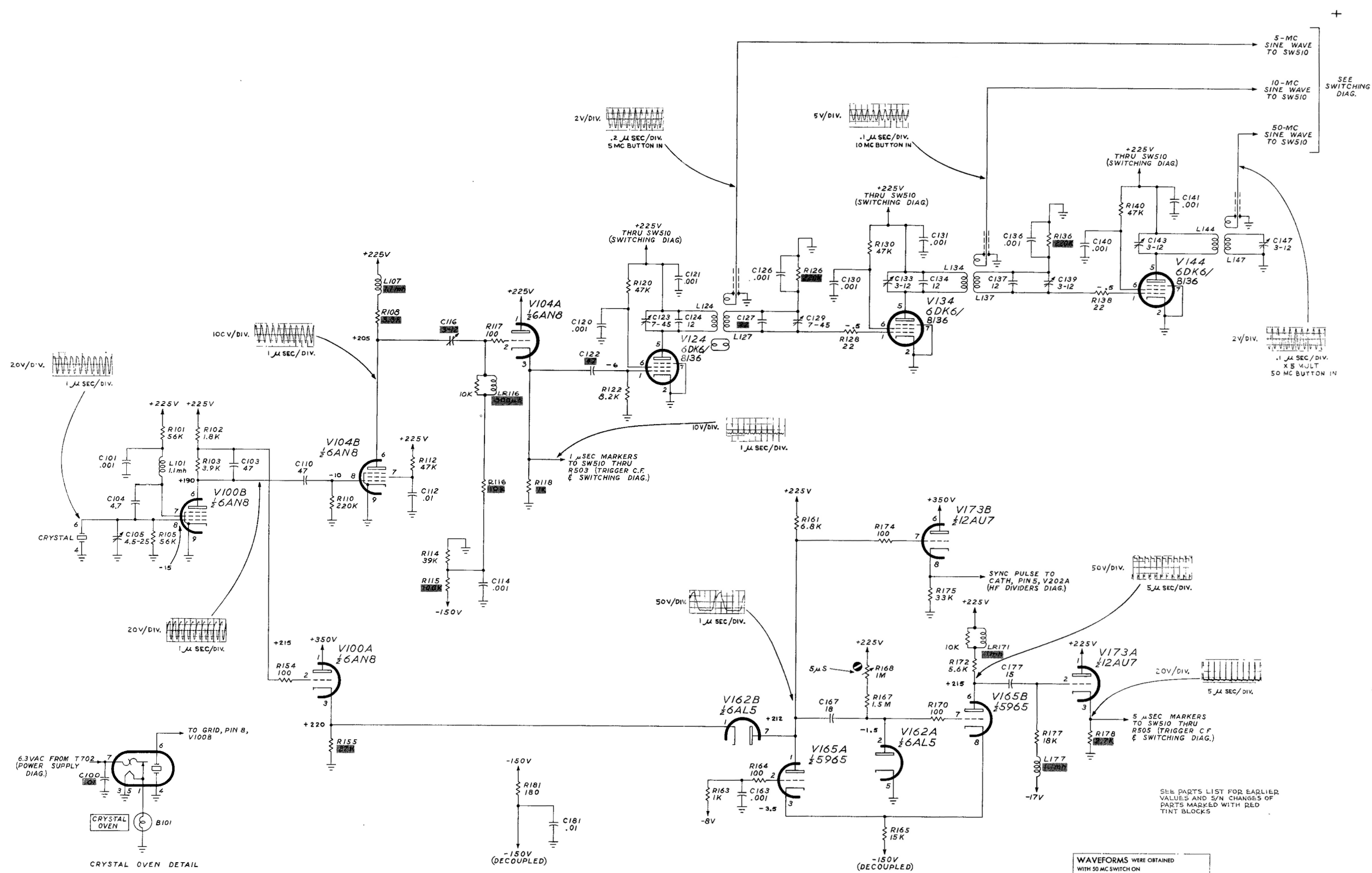

WAVEFORMS WERE OBTAINED WITH 50 MC SWITCH ON
 VOLTAGE READINGS WERE OBTAINED WITH SWITCHES CANCELED

CIRCUIT NUMBERS 100 THRU 185

OSCILLATOR & MULTIPLIER

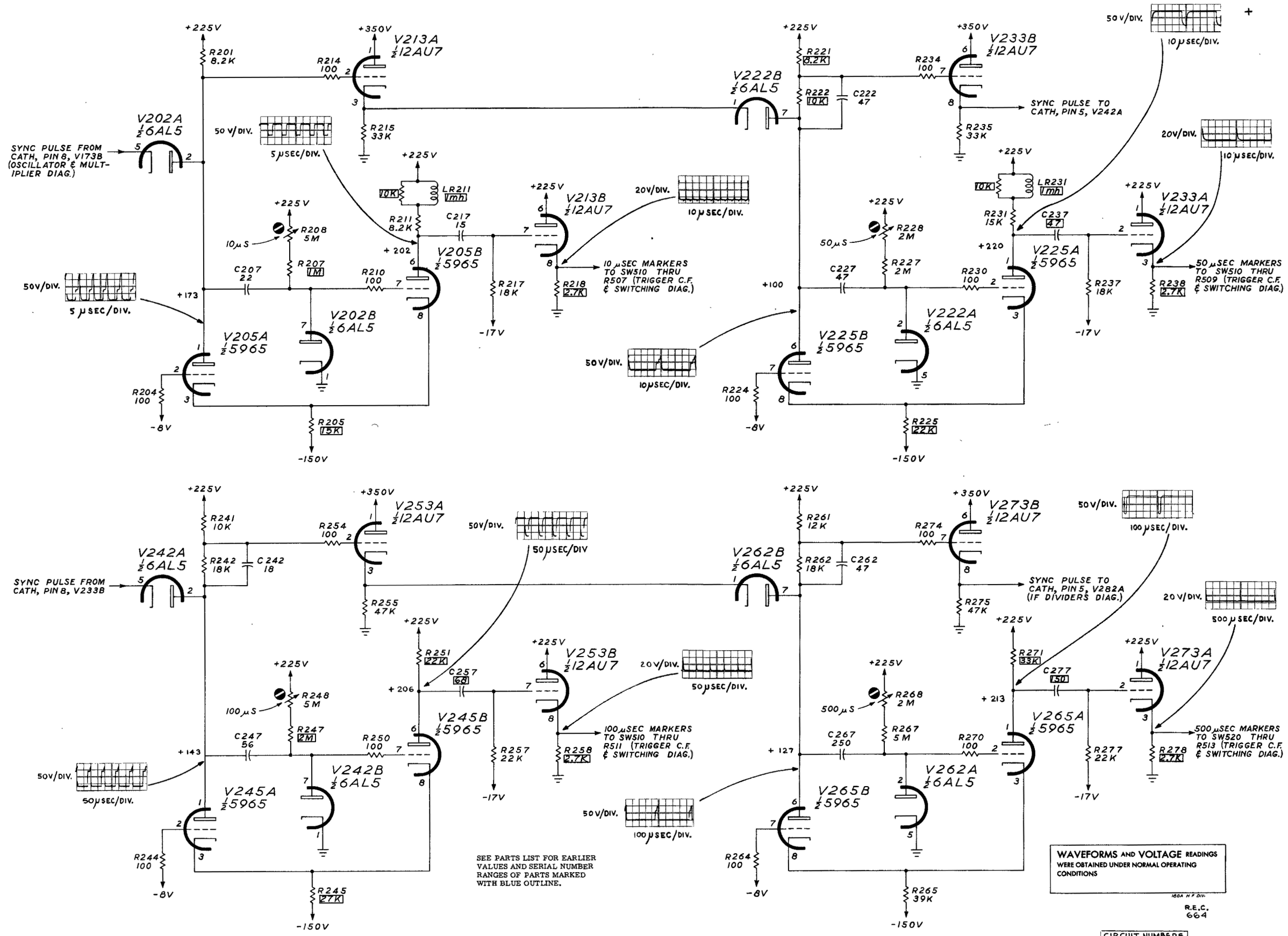

WAVEFORMS AND VOLTAGE READINGS WERE OBTAINED UNDER NORMAL OPERATING CONDITIONS

CIRCUIT NUMBERS 200 THRU 279

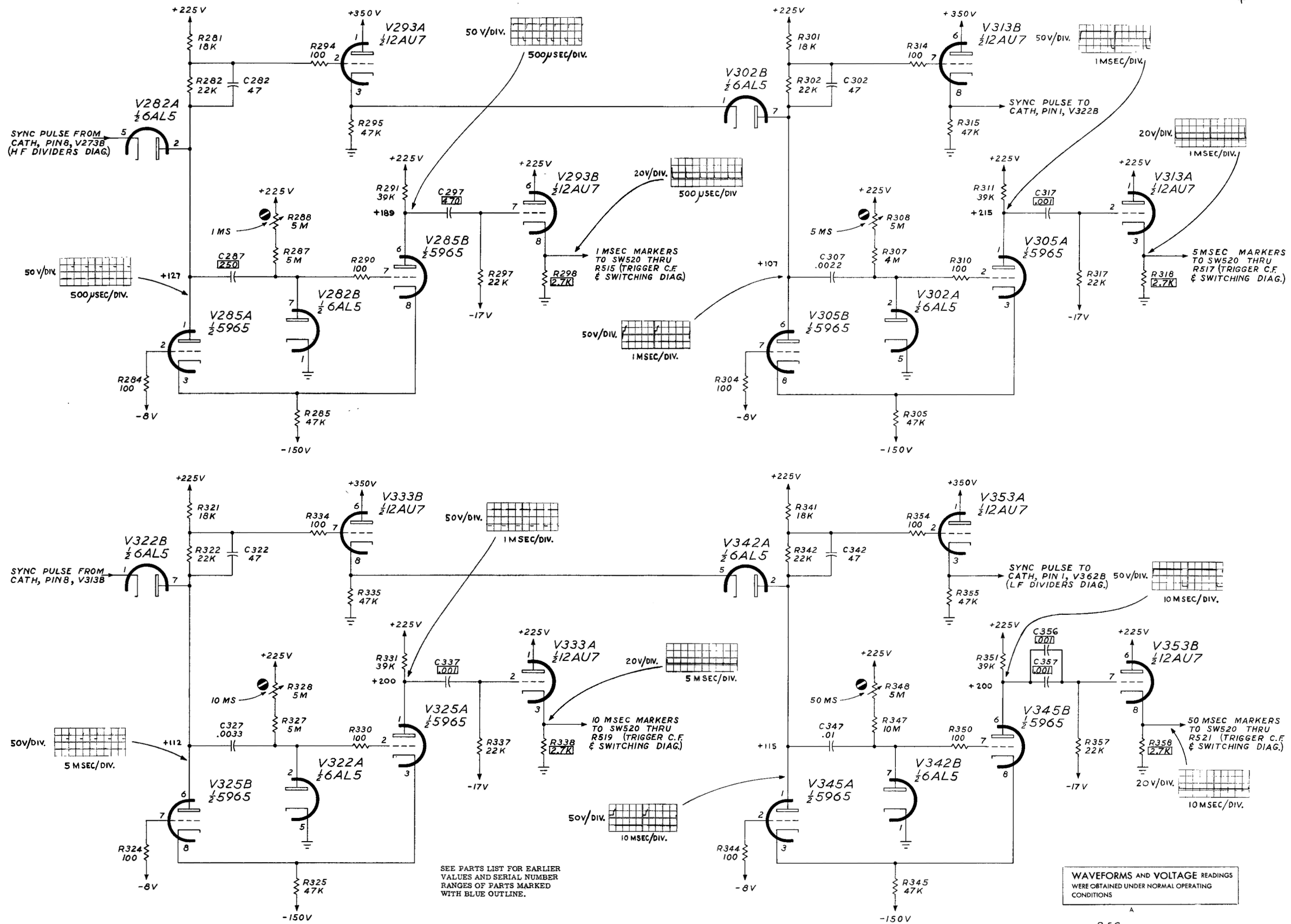

CIRCUIT NUMBERS
280 THRU 359

R.E.C.
664

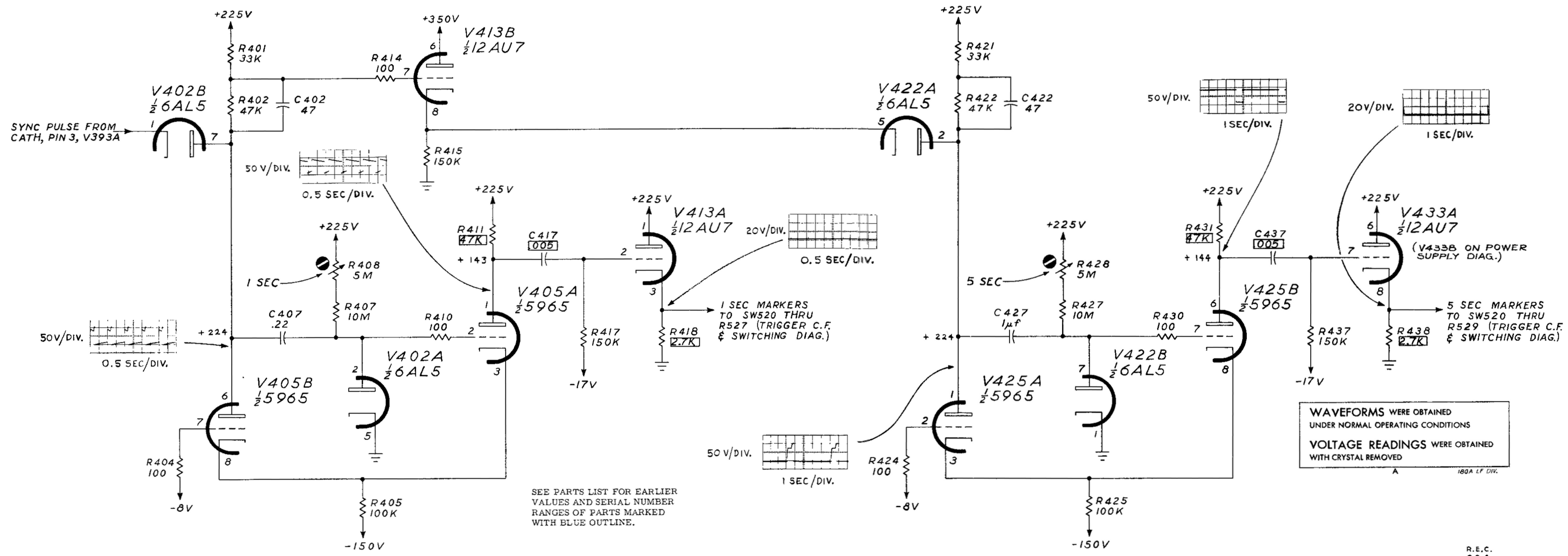
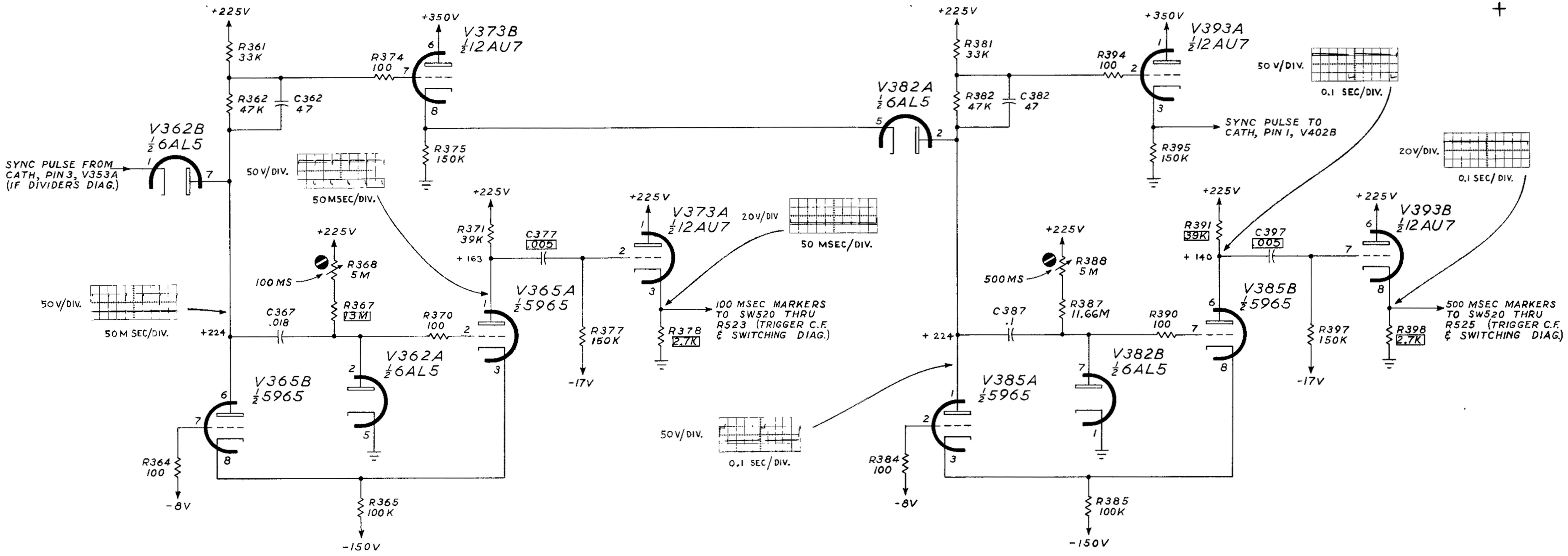

SEE PARTS LIST FOR EARLIER VALUES AND SERIAL NUMBER RANGES OF PARTS MARKED WITH BLUE OUTLINE.

WAVEFORMS WERE OBTAINED UNDER NORMAL OPERATING CONDITIONS
VOLTAGE READINGS WERE OBTAINED WITH CRYSTAL REMOVED
A 180A LF DIV.

R.E.C. 664

CIRCUIT NUMBERS 360 THRU 439

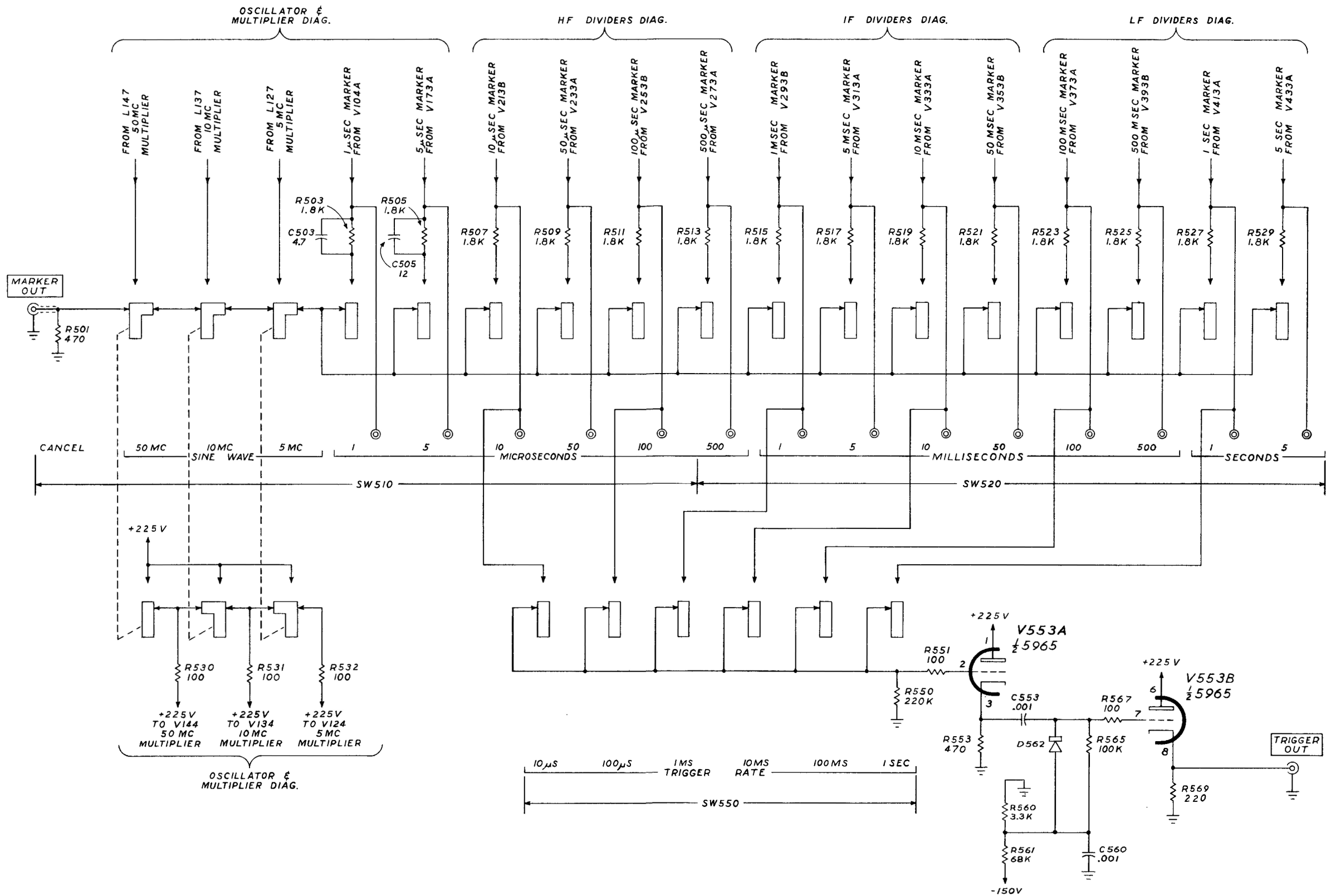

12-5-62
R.E.C.

OSCILLATOR & MULTIPLIER DIAG.

HF DIVIDERS DIAG.

IF DIVIDERS DIAG.

LF DIVIDERS DIAG.

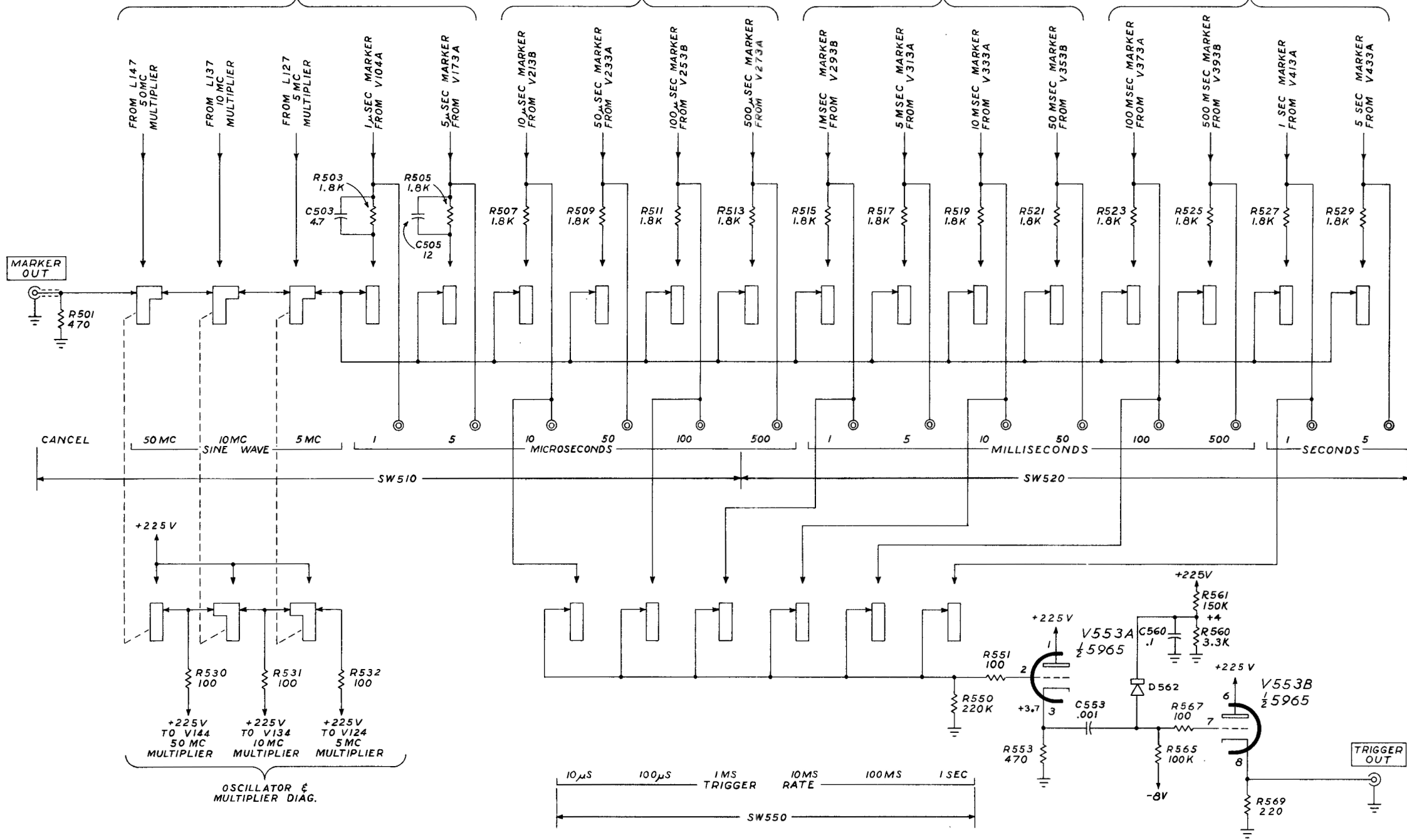

VOLTAGE READINGS WERE OBTAINED UNDER NORMAL OPERATING CONDITIONS
A 180A C.F. & SW.

CIRCUIT NUMBERS 500 THRU 570

12-5-62 R.E.C.

T701

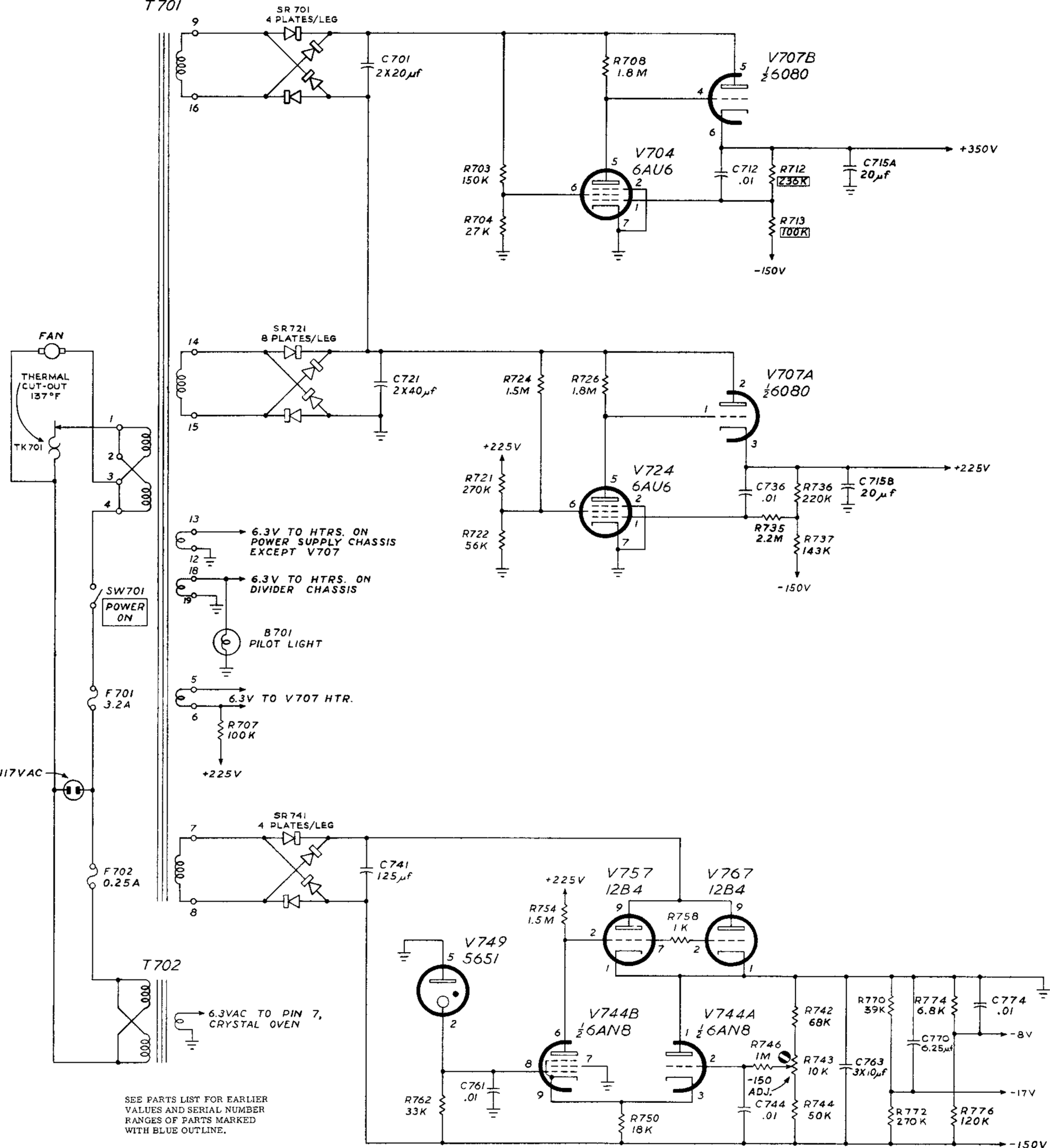

TYPE 180A TIME-MARK GENERATOR

AA₁

POWER SUPPLY

SN 5001-5478

R.E.C.
664

T701

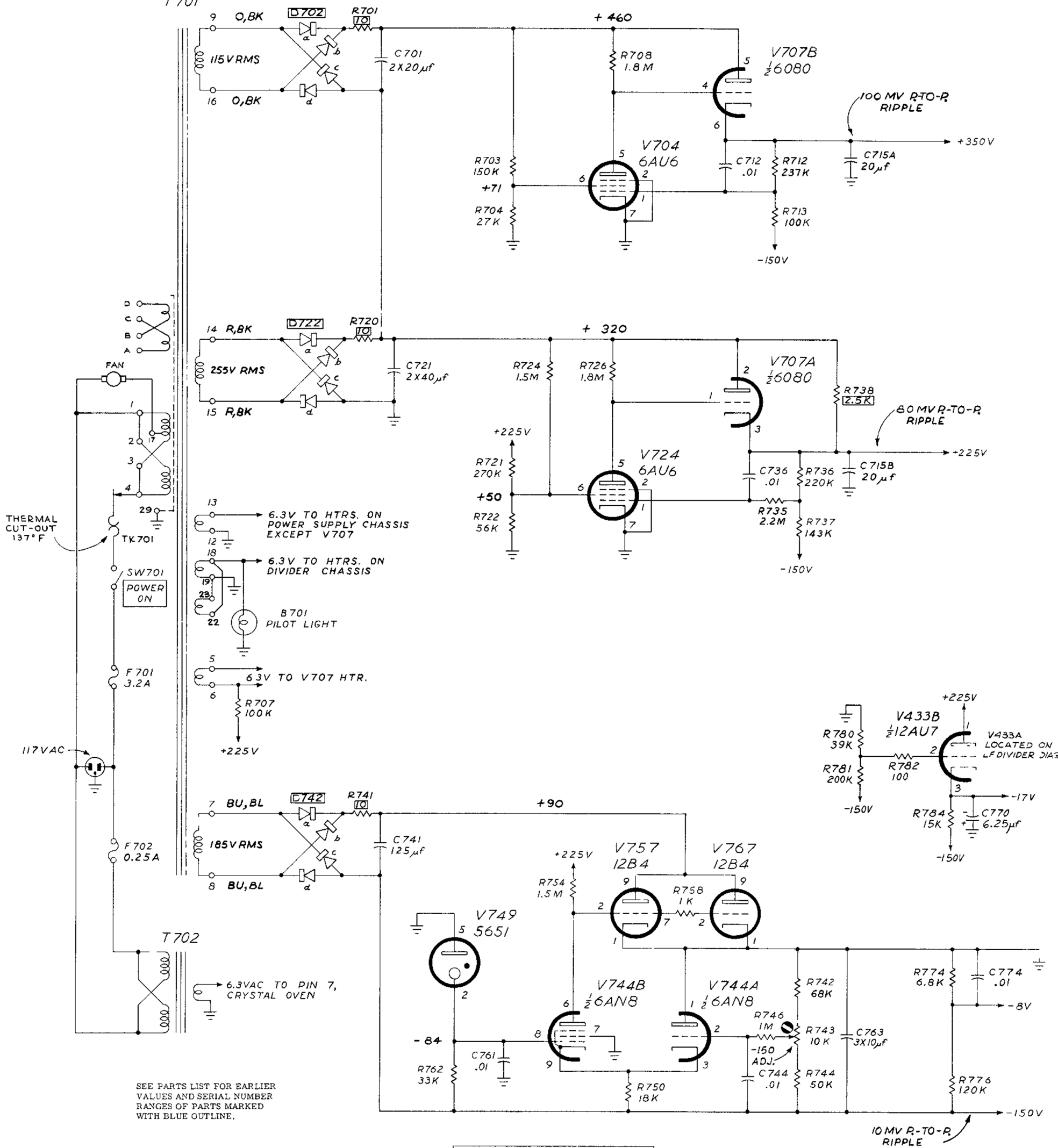

SEE PARTS LIST FOR EARLIER VALUES AND SERIAL NUMBER RANGES OF PARTS MARKED WITH BLUE OUTLINE.

VOLTAGE READINGS WERE OBTAINED UNDER THE FOLLOWING CONDITIONS.
 LINE VOLTAGE 117 V AC
 SWITCHES CANCELLED
 80% POWER SUPPLY

CIRCUIT NUMBERS 700 THRU 789

R.E.C. 664

POWER SUPPLY
 SN 5479-UP